

Assembly Instructions

⚠ Important ⚠

Before you begin, read and comply with all safety and operating instructions, and ensure all parts and correct quantities are included.

Any parts damaged during shipment must be reported within 5 days of receipt. To report information regarding missing parts or damage, to purchase parts or accessories, or if you have any questions, please contact us.

www.spectrumfurniture.com

800-235-1262, 715-723-6750

Thank you for purchasing Spectrum products!

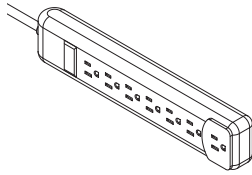

(1) 052741
7-Outlet Power Strip



6" Hook & Loop Strips
(1) 052309 - Hook
(1) 052310 - Loop

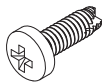

(2) 0100166
6-32 x 1/2" PH Thread-cutting screw
(used when mounting with keyhole slots on back of power strip)



7-Outlet Power Strip
99024

Note: Do not connect any electrical equipment to the power strip until it is mounted securely. Keep the power strip switched off until plugged into a wall outlet. To maintain UL-compliance, do not "daisy-chain" multiple power strips. See instructions included with the power strip for additional installation, operational, and safety instructions.

Desk Installation

1. Remove the backer from one hook or loop strip to expose the adhesive.
2. Center and attach the hook or loop to the back of the power strip.
Figure 1A.
3. Remove the backer from the second hook or loop strip, and attach to the vertical part of the cord channel shown in **Figure 1B.**
4. Press power strip into place.

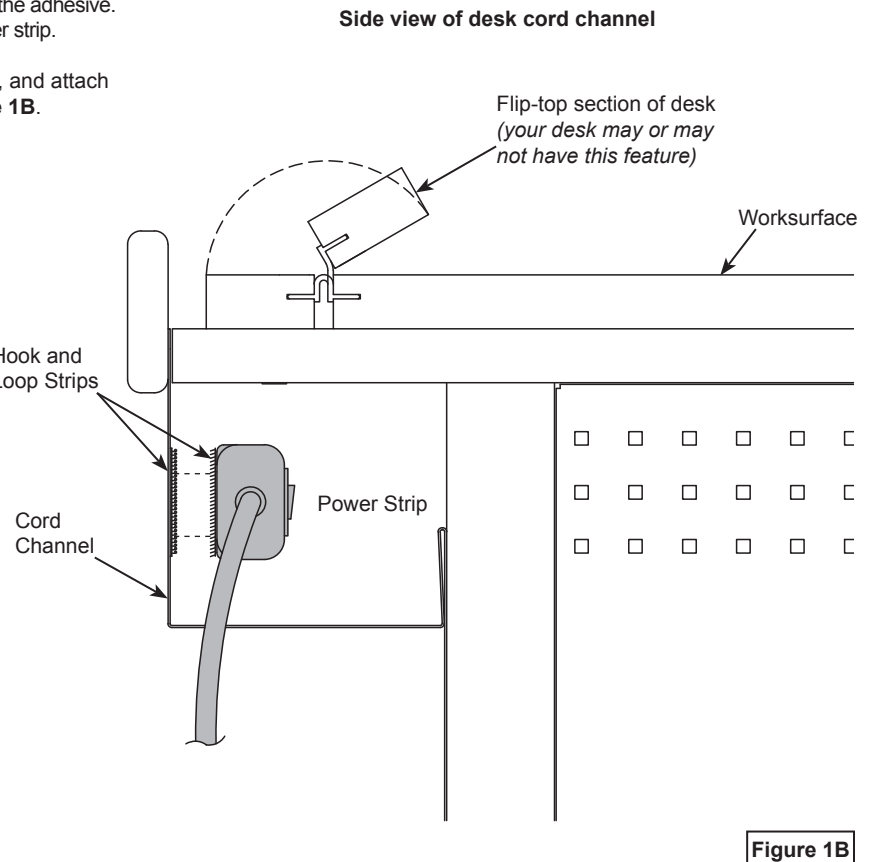
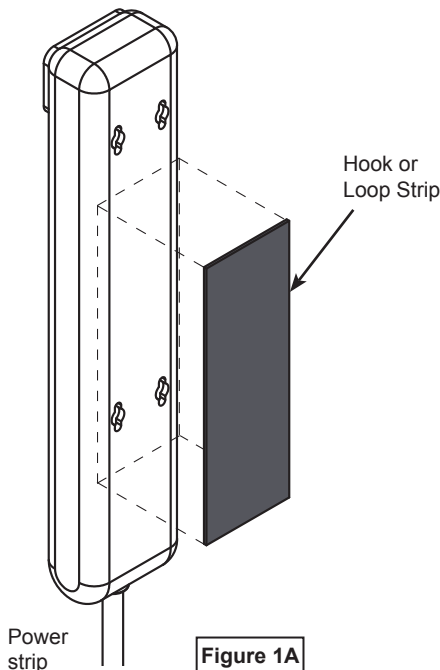

Cart / Lectern Installation

Hook and loop-mounting:

1. Remove the backer from one hook or loop strip to expose the adhesive.
2. Center and attach the hook or loop to the back of the power strip.
- Figure 2A.**
3. Remove the backer from the second hook or loop strip, and attach to the cart / lectern where needed.
4. Press power strip into place.

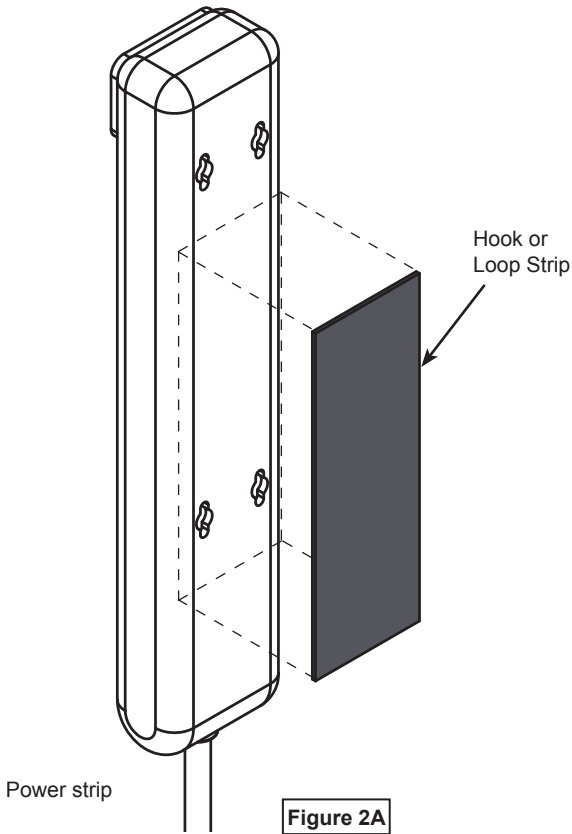

Figure 2A

Screw-mounting:

Note: Some Spectrum laptop carts include (2) mounting holes that accept the two enclosed 6-32 thread-cutting screws that are used with the key-hole slots on the back of the power strip.

1. Locate the two 7/64" holes on the cart (if equipped). **Figure 2B.**
2. Install the two 6-32 x 1/2" PH thread-cutting screws into the holes-leave about 1/4" of the screw threads exposed.
3. Align the power strip keyholes and set the power strip onto the screws. The screws can be adjusted to fine-tune the fit if necessary.

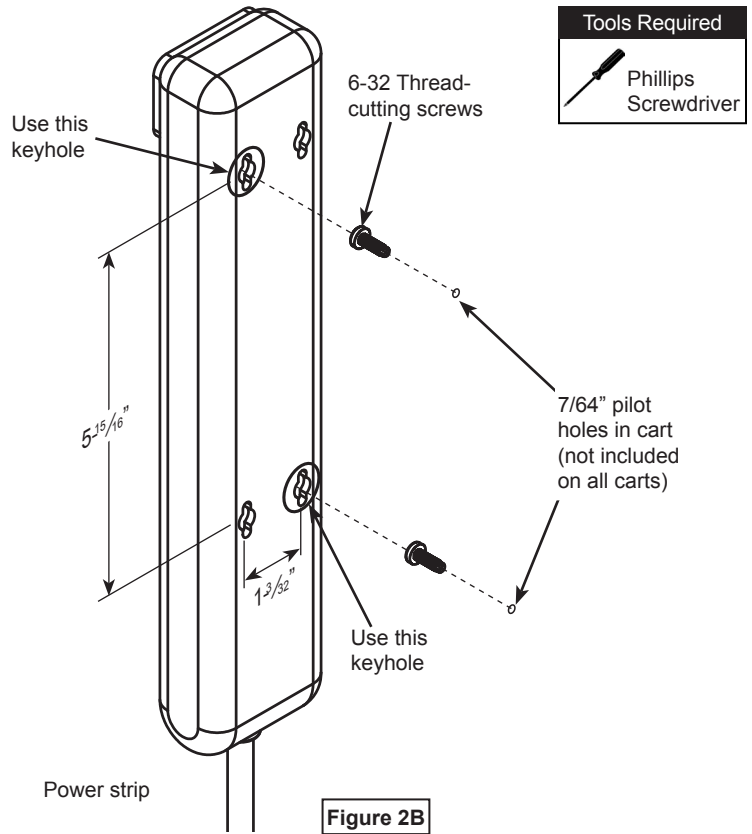

Figure 2B

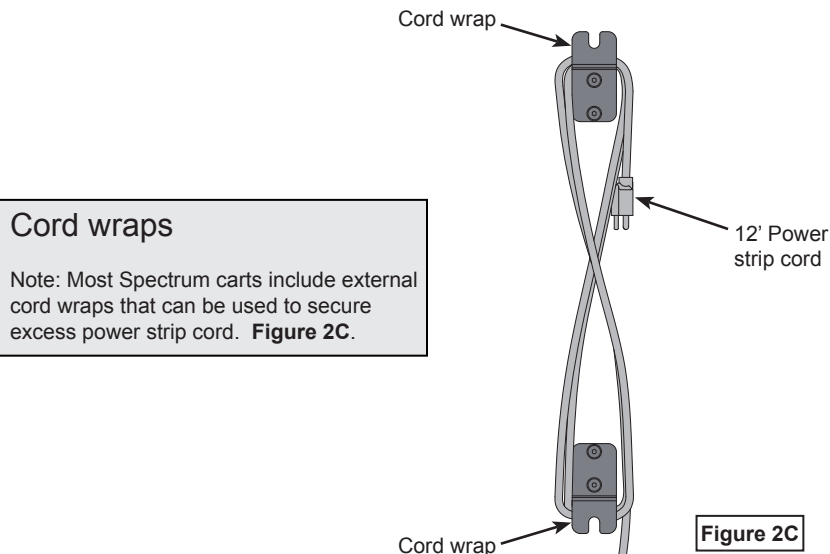

Figure 2C