

# Assembly Instructions

## ⚠ Important ⚠

Before you begin, read and comply with all safety and operating instructions, and ensure all parts and correct quantities are included.

Any parts damaged during shipment must be reported within 5 days of receipt. To report information regarding missing parts or damage, to purchase parts or accessories, or if you have any questions, please contact us.

[www.spectrumfurniture.com](http://www.spectrumfurniture.com)  
800-235-1262, 715-723-6750

Thank you for purchasing Spectrum products!

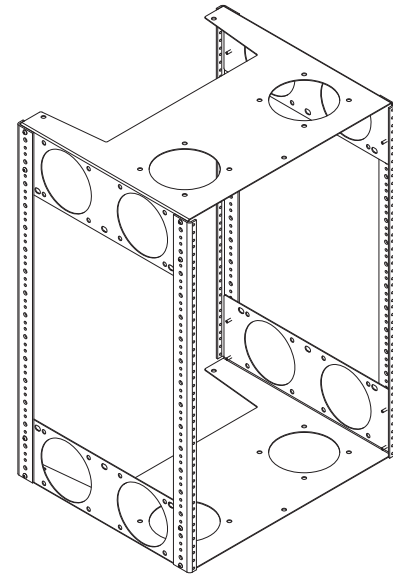

## 16RU Rack Cube 55108

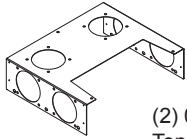

(2) 0118596  
Top / Bottom Panel



(1) 0101382  
#14 x 7/8" PHSM  
screw



(2) 0115173  
1"W x 18.5"L  
Polyethylene slide  
with (S1101) 3/4"  
double-sided tape



(16) 0100167  
8-32 x 1/2" PH  
thread-cutting  
screw



(4) 055486  
Rack rail (28")

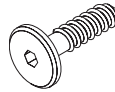

(4) 0102297  
7mm x 30mm JCW  
screw



(4) 0107139  
Bumper Stop



(1) 025039  
4mm Hex  
wrench

Tools Required



Drill with  
Phillips  
driver



Phillips  
Screwdriver



4mm Hex  
Wrench  
(included)

## 1. Assemble Cube

1. Assemble the cube top, bottom, and four rack rails using (16) 8-32 x 1/2" PH thread-cutting screws. Note the orientation of the rails. **Figure 1.**
2. Tighten screws securely.

8-32 x 1/2" PH  
thread-cutting screw  
(16 required)

Rack rail  
(X 4)

Top  
panel

Bottom  
panel

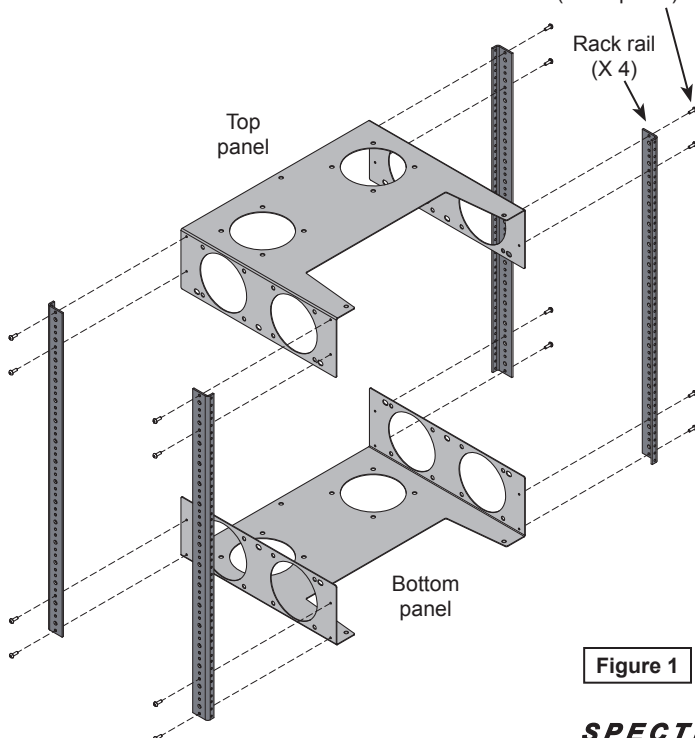

Figure 1

## 2. Apply Slides

1. Apply the polyethylene slides to the bottom panel as shown. **Figure 2.**

Note: Each slide should be placed approximately 5/8" away from the edge of the rack cube.

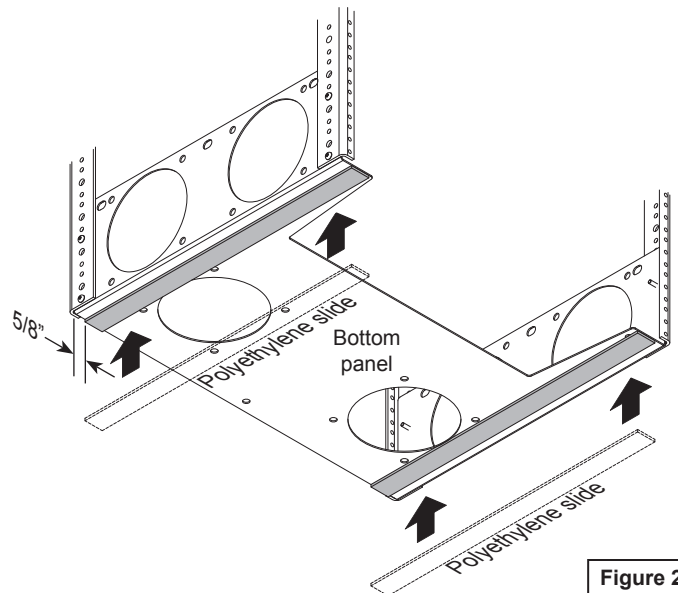

Figure 2

### 3. Install Cube

1. Using the quick-release, remove the door to provide better access.
2. Install the (4) bumper stops to the base panel as shown with one 7mm x 30mm JCW screw each. **Figure 3.**
3. Place the cube assembly into the lectern.
4. Secure the cube to the base panel with (1) #14 x 7/8" PHSM screw and tighten securely.
5. The bumper stops can be rotated if adjustment is necessary.

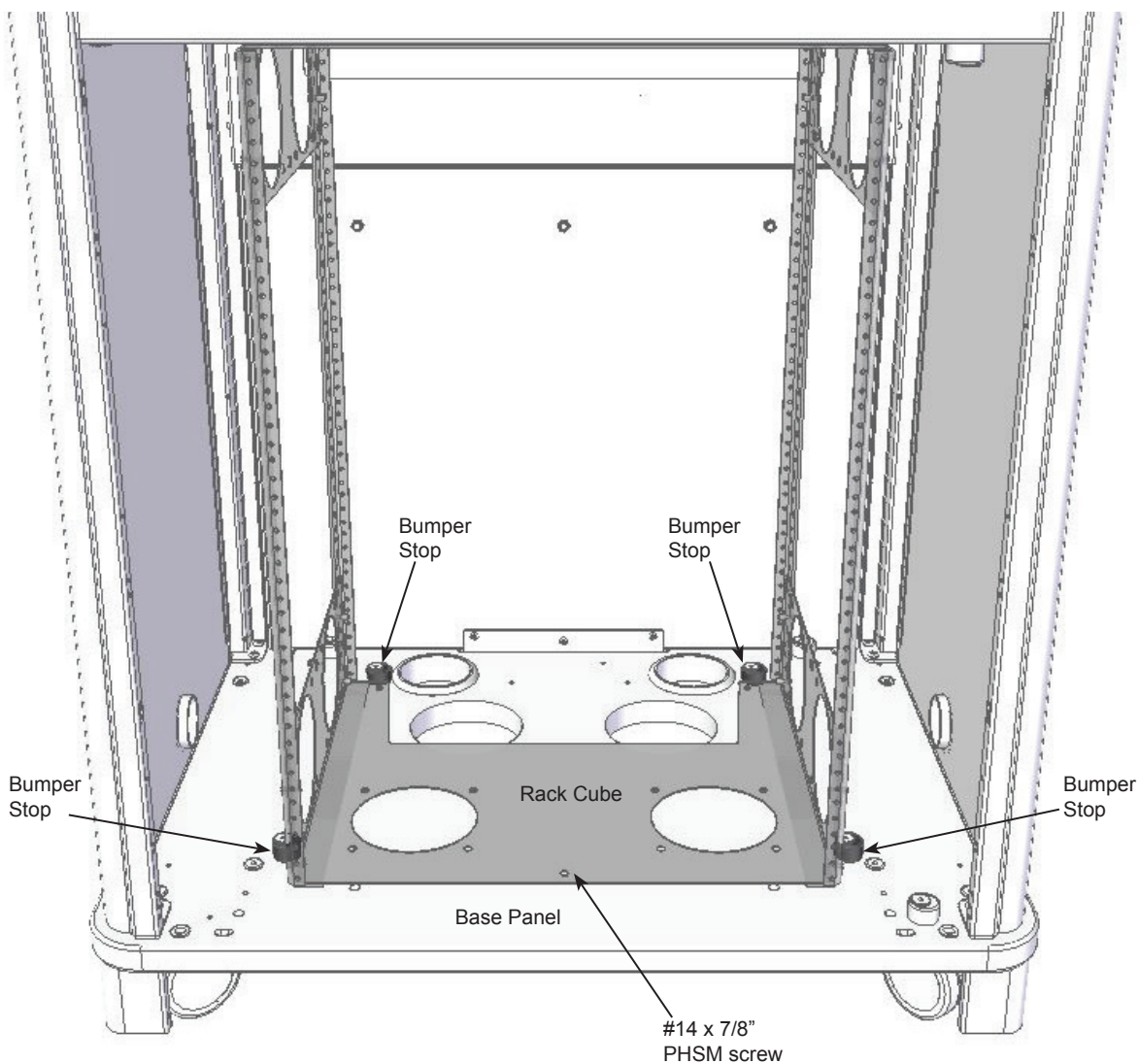

Figure 3

The rack cube provides 16RU of rack space and is easily removed from the lectern. This simplifies installation of equipment and provides the ability to integrate equipment remotely. The cube can be installed into the lectern at a later date or when convenient.

The cube also provides mounting capabilities for multiple cooling fans if necessary. Compatible with most 4.75" cooling fans with 4.13" mounting hole spacing (12 mounting locations available).