

# Assembly Instructions

## ⚠ Important ⚠

Before you begin, read and comply with all safety and operating instructions, and ensure all parts and correct quantities are included.

Any parts damaged during shipment must be reported within 5 days of receipt. To report information regarding missing parts or damage, to purchase parts or accessories, or if you have any questions, please contact us.

[www.spectrumfurniture.com](http://www.spectrumfurniture.com)

800-235-1262, 715-723-6750

Thank you for purchasing Spectrum products!

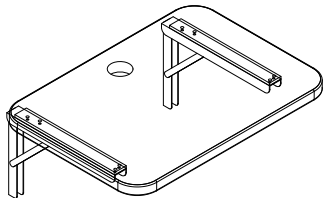

(1) 0120378  
Flip-up shelf assembly



(1) 039622  
2" Grommet

*For metal side panels*



(4) 0100167  
8-32 x 1/2" PH  
Thread-cutting screw

*For laminate side panels*

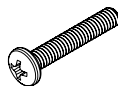

(4) 051696  
8-32 x 1" PHMS



(4) 0285  
3/16 Flat Steel  
Washer



(4) 021588  
8-32 Keps Nut

Tools  
Required



Phillips  
screwdriver

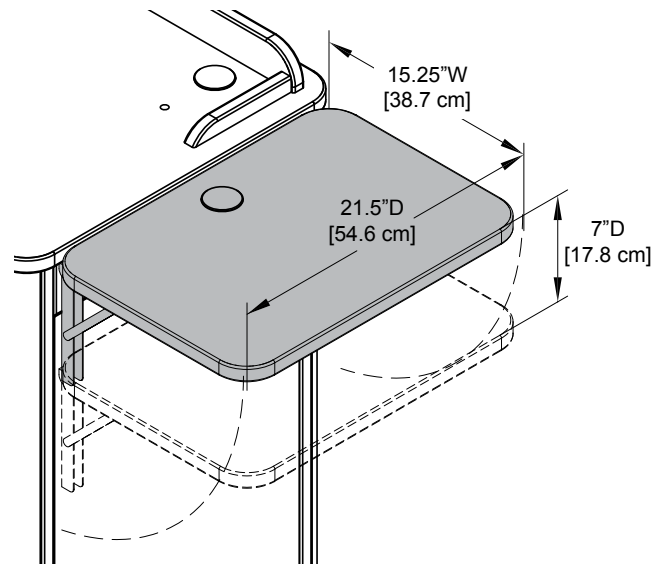

## Flip-up Shelf for Compact Lectern™ 55109

## 1. Before You Begin

### Determine:

- Side of the lectern the shelf will be installed. (Left or right-side)
- Upper or lower shelf position
- Type of side panels your lectern has (metal or laminate) **Figure 1A**

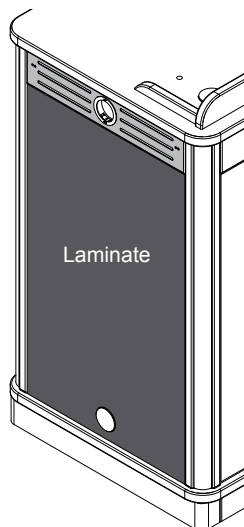
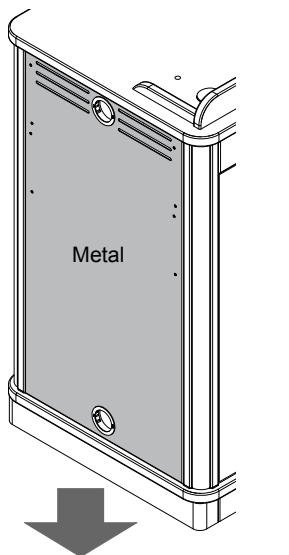

Proceed to Step 2

**Figure 1A**

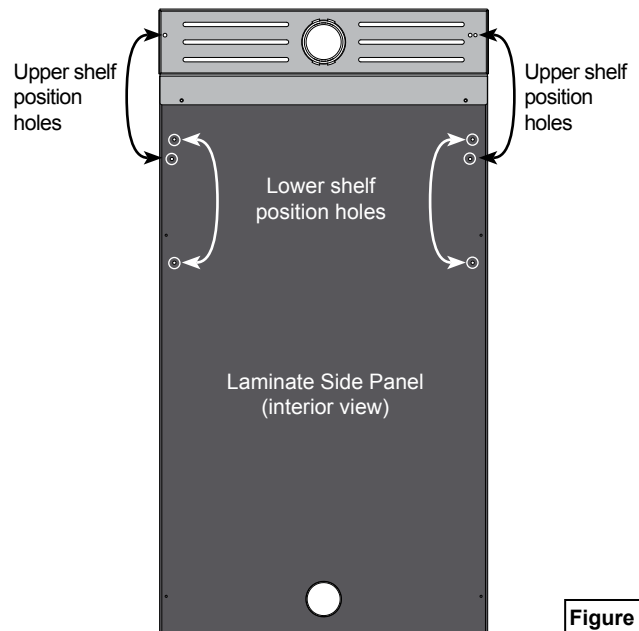

**Figure 1B**

### Attaching to Laminate Side Panels:

1. Open the lectern door and remove the rack cube (if equipped).
2. From inside the lectern, use a drill with a 3/16" drill bit and slowly drill out the corresponding pre-drilled pilot holes located on the laminate side panel. **Figure 1B**. Masking tape can be used on the exterior to minimize chip-out.



Note: There are (2) holes needed for the upper position, and (4) needed for the lower position.

Drill with  
3/16" drill bit

## 2. Attach Shelf Brackets to Lectern

1. Remove the instructor-side door and audience-side panel.
2. Extend and lock each folding shelf bracket into the horizontal position. **Figure 2A.**
3. Align and attach each bracket to the side of the lectern using:

<b>Metal side panels</b>	<b>Laminate side panels</b>
<b>Figure 2A</b>	<b>Figure 2B</b> (a 2nd person to assist may be required)
(4) 8-32 x 1/2" PH Thread-cutting screws	(4) 8-32 x 1" PHMS (4) 3/16" Flat steel washers (4) 8-32 Keps nuts

4. Tighten all screws securely.
5. Install 2" grommet in shelf.

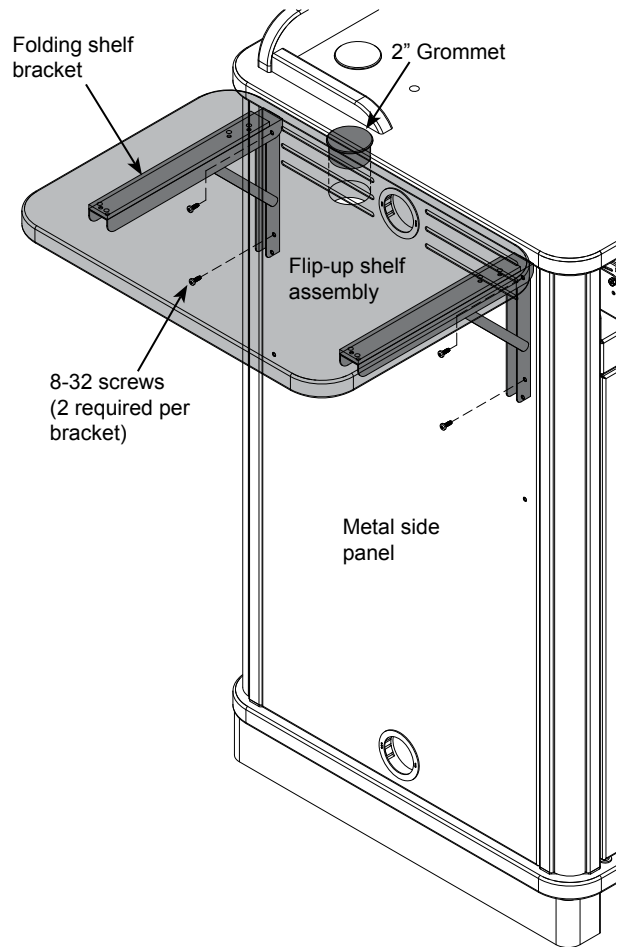

**Figure 2A**

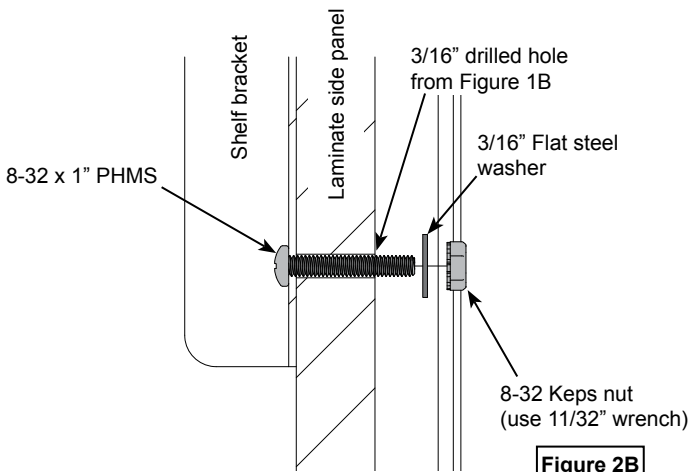

**Figure 2B**

## 3. Operation

The shelf will automatically lock into place when lifted into the horizontal position with the levers released. **Figure 3.** To lower or flip-up the shelf, press and hold the levers under each folding shelf bracket at the same time while slowly lowering or raising the shelf. Do not exceed a maximum of 35 lb of weight on the shelf. Do not move the lectern while the shelf is in the horizontal position.

Note: Power and communication wiring for document cameras, laptop computers, and / or projectors placed on the flip-up shelf should be routed on top of the audience-side of the shelf. Use of the shelf grommet hole for wiring will result in pinching of the cords when the shelf is folded.



**CAUTION**  
Keep clear of pinch points during shelf movement.  
Do not exceed 35 lbs [15.9 kg] of weight on shelf.

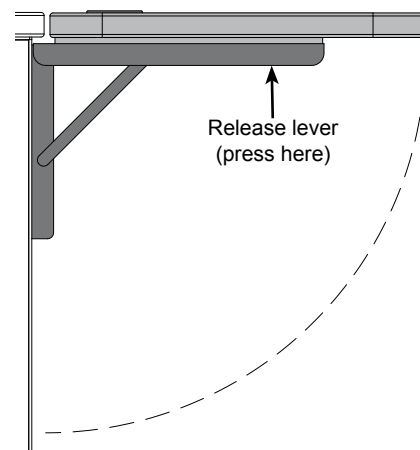

**Figure 3**