

# Assembly Instructions

## ⚠ Important ⚠

Before you begin, read and comply with all safety and operating instructions, and ensure all parts and correct quantities are included.

Any parts damaged during shipment must be reported within 5 days of receipt. To report information regarding missing parts or damage, to purchase parts or accessories, or if you have any questions, please contact us.

**www.spectrumfurniture.com**  
800-235-1262, 715-723-6750

*Thank you for purchasing Spectrum products!*

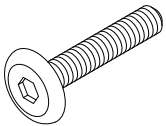

(4) 0102063  
1/4-20 x 35mm  
JC bolt



(4) 041943  
1/4-20 Locknut

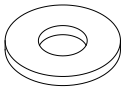

(4) 026059  
1/4" Flat Washer

The overbridge can be free-standing or anchored to the worksurface. The following instructions show anchorage procedure.

## 1. Locate mounting holes

1. Locate the overbridge on the worksurface in the preferred final mounting position making sure the overbridge and fasteners do not interfere with grommets or anything under the worksurface.
2. Mark the (4) mounting hole locations on the worksurface and remove the overbridge.

### Figure 1.

3. Carefully drill all the way through the worksurface at the hole locations with a 5/16" drill bit.

Note: Use a sharp drill bit and drill slowly through the worksurface to minimize laminate chipping around the holes.

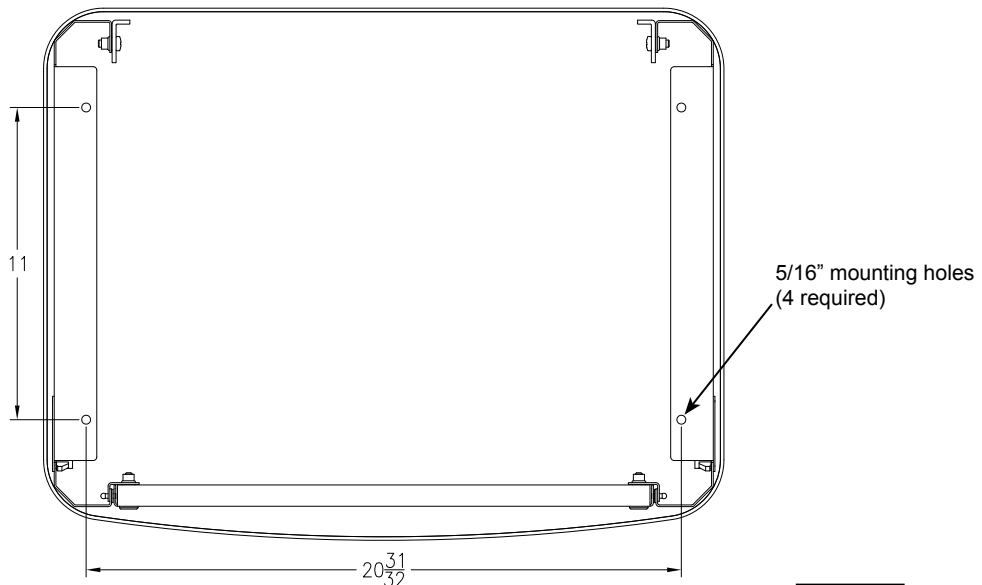

**Figure 1**

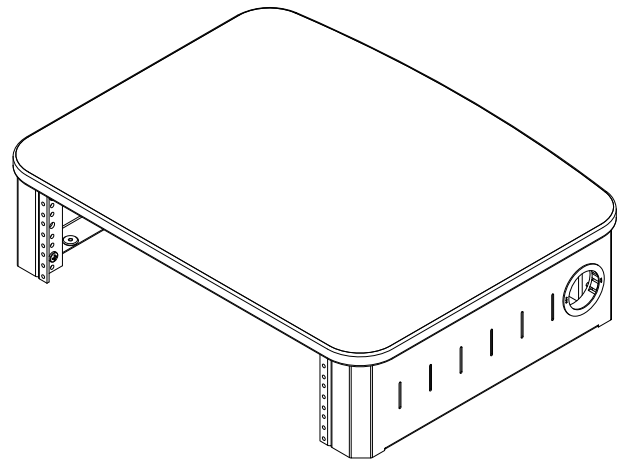

## Overbridge with Rack Rail (3RU) 95003

### Tools Required



Drill



5/16"  
Drill bit



7/16" or  
Adjustable  
wrench



4mm Hex  
wrench

## 2. Attach overbridge

1. Align the overbridge with the mounting holes. **Figure 2A.**
2. Place a 1/4-20 x 35mm JC Bolt in each hole, followed by a washer and a locknut. **Figure 2B.**
3. Using a 4mm hex wrench and adjustable wrench, tighten the four bolts securely.

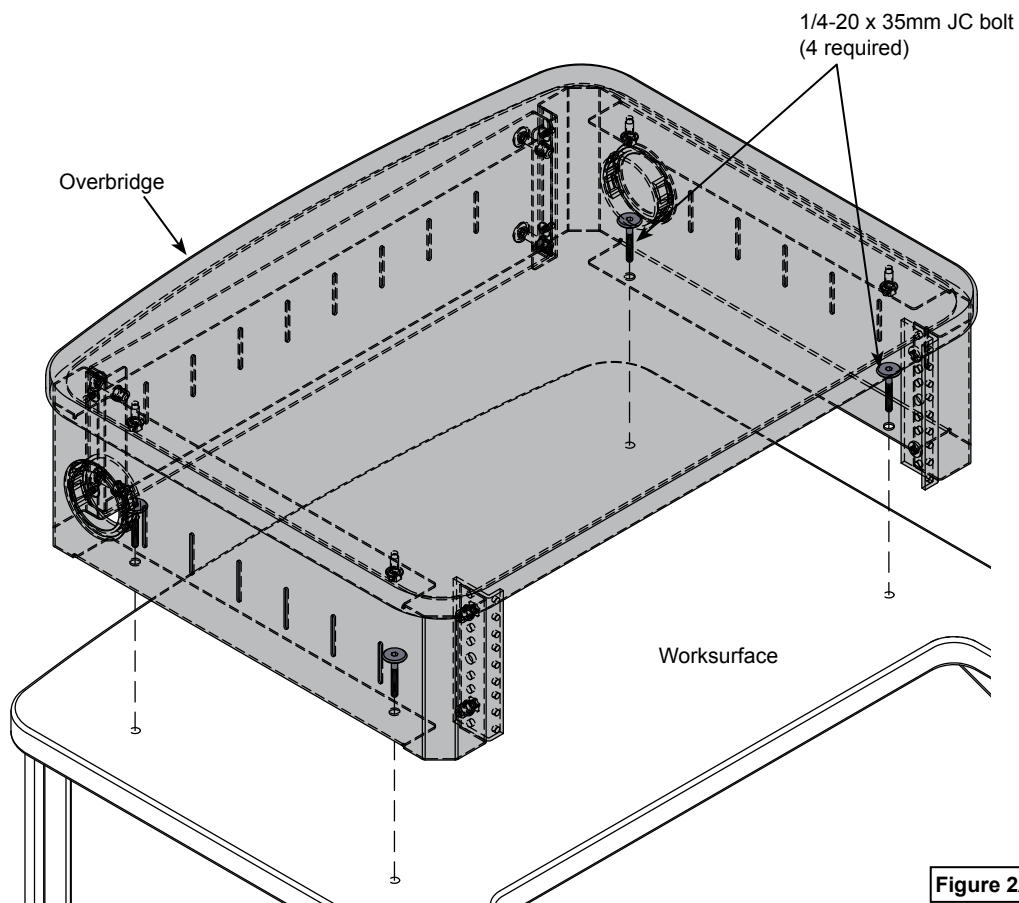

Figure 2A

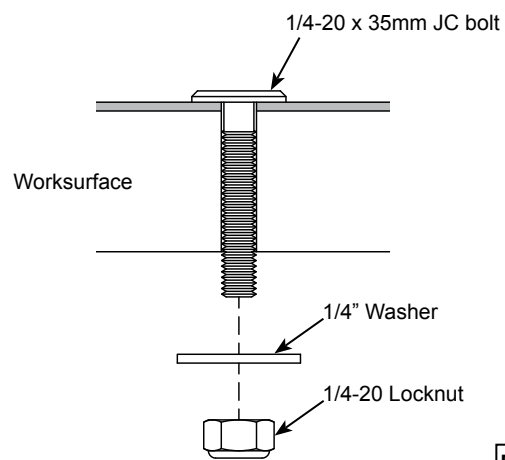

Figure 2B