

# Assembly Instructions:

To purchase parts or accessories, please contact us at  
[www.spectrumfurniture.com](http://www.spectrumfurniture.com)  
 1-800-235-1262  
 Thank you for choosing Spectrum products!



044541  
 1/4-20 x 20mm JC bolt  
 (13) for cord channel  
 (8) for modesty panel



(1) 025039  
 4mm Hex wrench

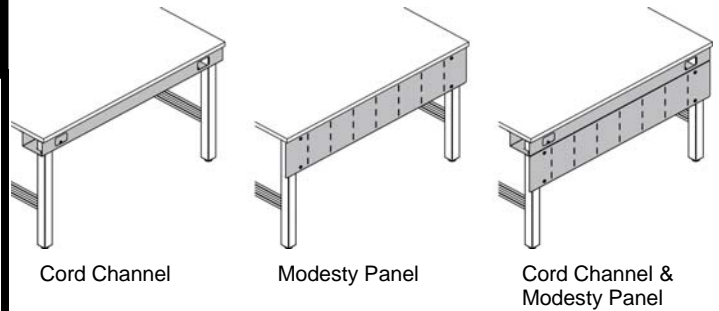

Cord Channel

Modesty Panel

Cord Channel & Modesty Panel

## Cord Channel / Modesty Panel for Flex Training Tables

**Cord Channel**  
 37256 - for 48" table  
 37257 - for 60" table  
 37258 - for 72" table

**Modesty Panel**  
 37253 - for 48" table  
 37254 - for 60" table  
 37255 - for 72" table

Before you begin, please make sure all parts and proper quantities are included. Any parts damaged during shipment must be reported within 15 days of receipt. To report information regarding damages or if you have any questions, please call 1-800-235-1262.

**Tools Required:**  
 Phillips screwdriver  
 4mm Hex wrench (included)

## Attaching cord channel to table

- Flip the table upside-down onto a non-abrasive surface.
  - Remove the 4 rear-most PHM screws from each leg mounting plate.
  - Attach the front half of the cord channel to the work surface (through the leg mounting plates) as shown using 1/4-20 JC bolts and tighten securely. **Figure 1.**
  - Attach the rear half of the cord channel to the work surface (through the leg mounting plates) as shown using 1/4-20 JC bolts and tighten securely.
- Note:** The hole in the center of the mounting flange does not require a JC bolt into the work surface.
- Align the cord channel mounting holes from both halves, and attach together with JC bolts.
- Note:** The rear half will overlap the front, and the JC bolts will thread into the front half.

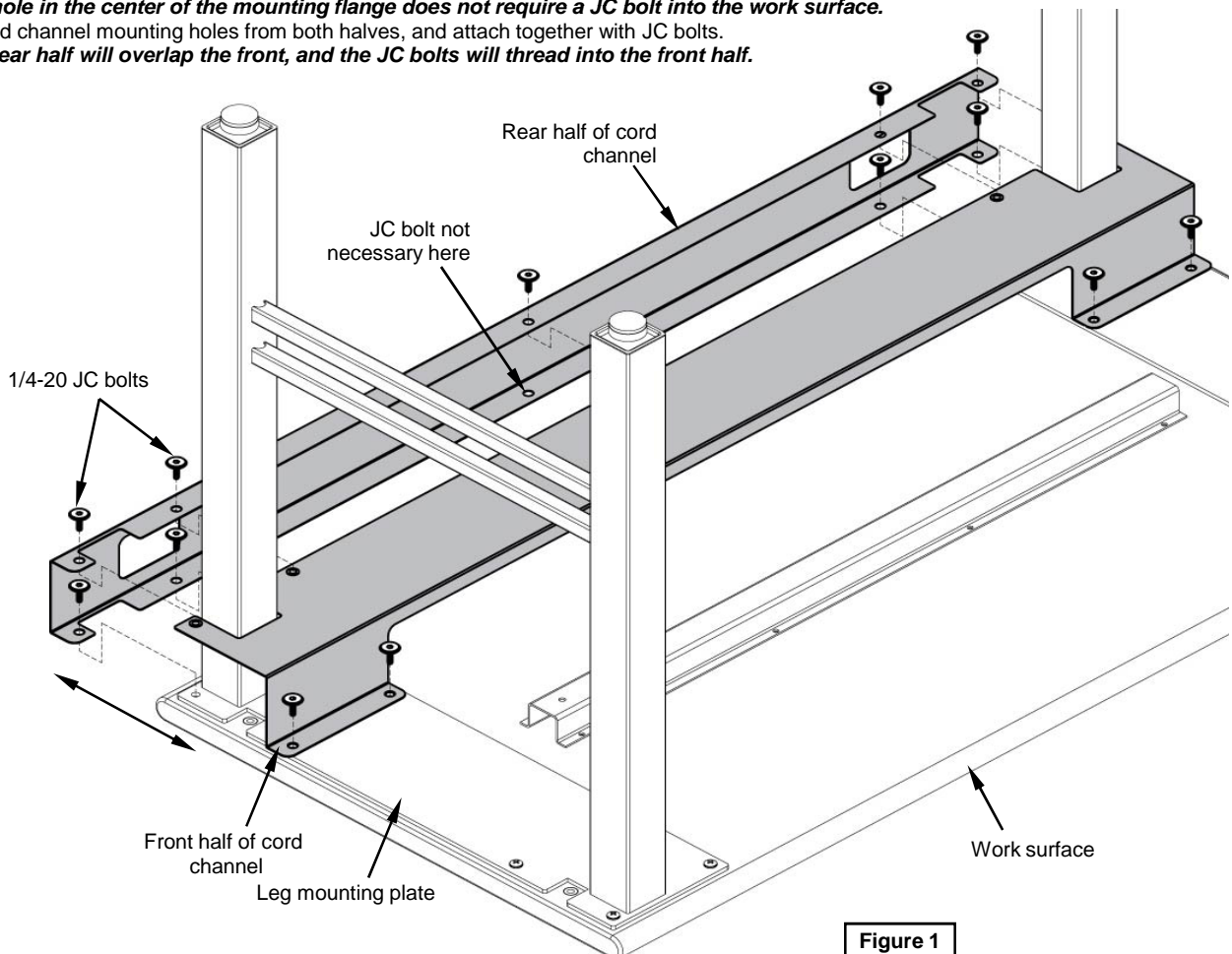
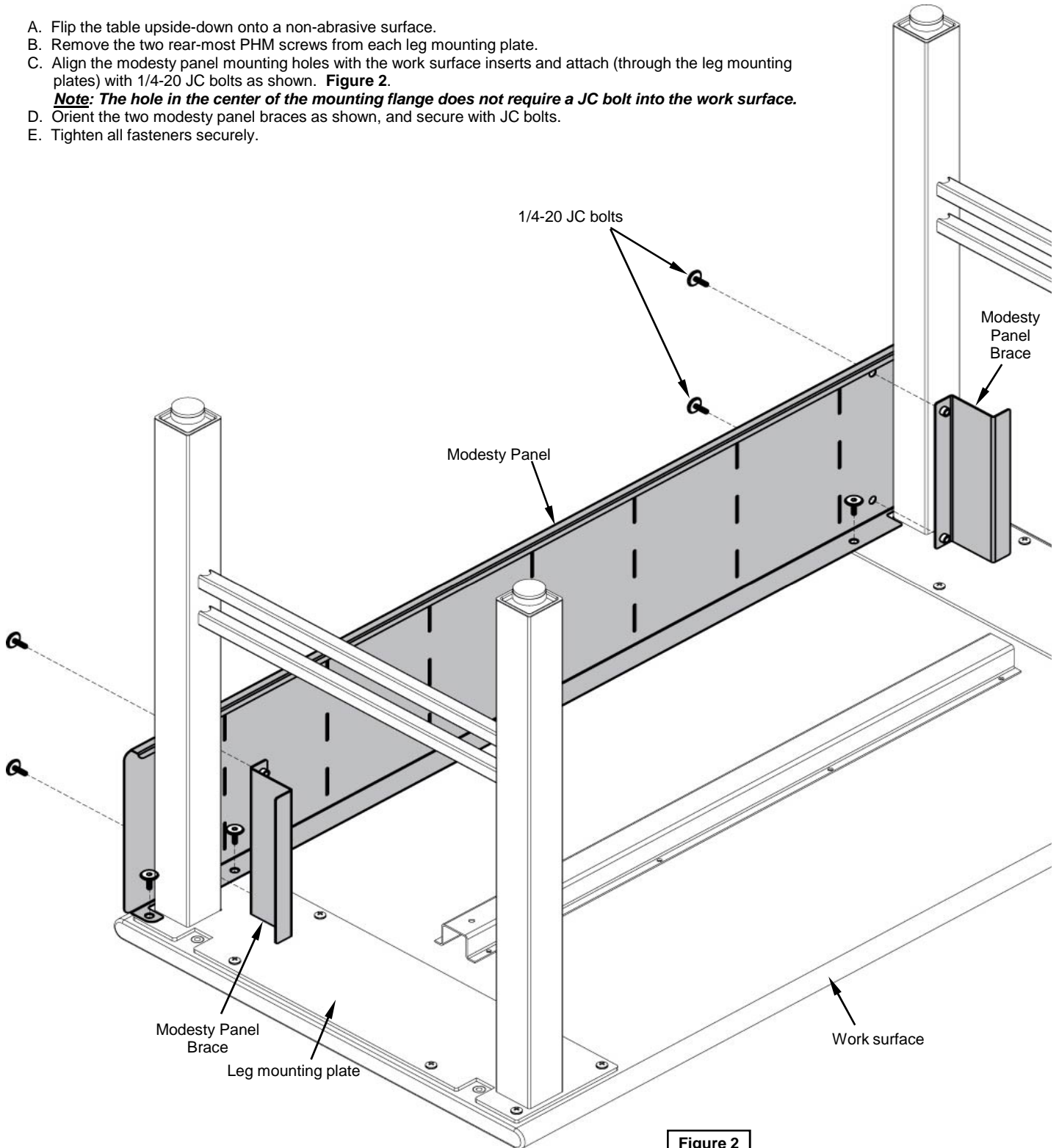

Figure 1

## Attaching modesty panel to table

- A. Flip the table upside-down onto a non-abrasive surface.
- B. Remove the two rear-most PHM screws from each leg mounting plate.
- C. Align the modesty panel mounting holes with the work surface inserts and attach (through the leg mounting plates) with 1/4-20 JC bolts as shown. **Figure 2.**
- Note: The hole in the center of the mounting flange does not require a JC bolt into the work surface.**
- D. Orient the two modesty panel braces as shown, and secure with JC bolts.
- E. Tighten all fasteners securely.



## Attaching cord channel with modesty panel to table

- A. Flip the table upside-down onto a non-abrasive surface.
- B. Remove the 2 rear-most PHM screws from each leg mounting plate.
- C. Attach the front half of the cord channel to the work surface (through the leg mounting plates) as shown using 1/4-20 JC bolts and tighten securely. **Figure 3.**
- D. Attach the rear half of the cord channel to the work surface (through the leg mounting plates) as shown using 1/4-20 JC bolts and tighten securely.
- E. Align the modesty panel mounting holes with the cord channel mounting holes from both halves, and attach with JC bolts. **Note: The rear half of the cord channel will overlap the front half, with the modesty panel attaching to both.**
- F. Orient the two modesty panel braces as shown, and secure with JC bolts.
- G. Tighten all fasteners securely.

