

Technical Specifications

55556

Connect16 prewired w/ USB-C PD charging

55556-USBC

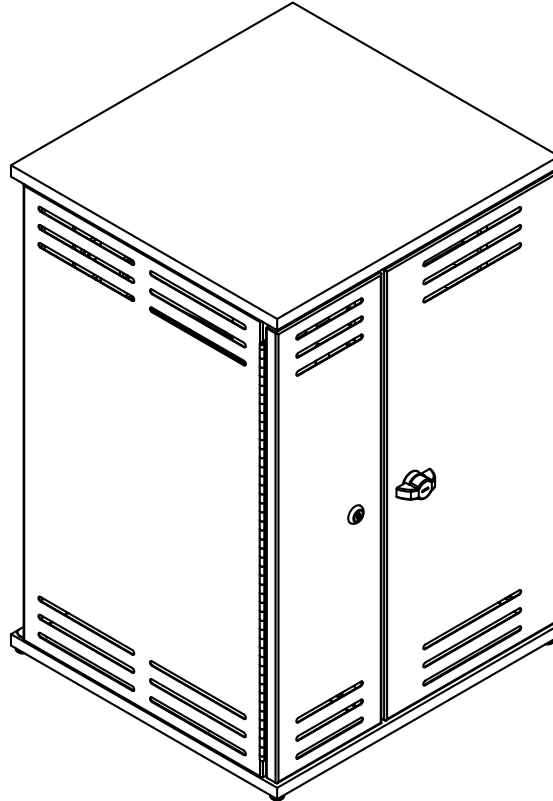

Use the Connect16 Locker to store and charge up to 16 devices in one location.
(most Chromebooks™, tablets, or notebooks up to 15")

Features and Benefits

- Stacked design stores and charges up to 16 tablets, Chromebooks™, or notebooks in one small footprint
- Overall dims: 18"W [45.72 cm] x 17"D [43.19 cm] x 26.8125"H [68.11 cm]
- Device shelves are undercut to make it easier to remove devices
- Single cam lock with magnetic closure provides added security
- Rubber feet prevent locker from sliding on surfaces
- Separate locking power bay provides storage for inline adapters. Provides easy-access to electrical power while keeping line voltage, wiring, and cords away from students
- Shelf can be removed to create more space for wall adapter storage
- 16-outlet (125V~/12A, 60Hz) power unit works with both inline, and wall adapters
- Internal on/off switch
- Outlets work with in-line and our 65W USB-C PD AC adapters
- Cord management system keeps charge cords organized next to each storage bay
- Long, 12' power cord provides easy access to outlets
- Ventilated door and side panels keep devices cool, preventing overheating, and extending device life
- Magnetic catch on power-side door prevents opening when unlocked
- Rear grommet for power cord management
- Locker ships fully-assembled for quick, simple integration and deployment
- Durable powder coated steel chassis provides a long lasting finish
- Warranted to be free of all defects in materials and workmanship for 10 years, electrical system 2 years
- Designed and assembled in Chippewa Falls, WI, USA

Color Options

Warm Gray
(metal)



Black
(laminated)

Construction

- The top and base are constructed from 3/4" thick composite board with .030" high-pressure laminate on one face, and a balancing phenolic backer on the opposing face
- Metal components consist of 16-gauge steel
- 20-gauge side panels, shelf supports and doors
- Device shelves are ABS plastic
- All metal components are finished with a scratch-resistant powder coat epoxy
- Each Connect16 Locker is factory-assembled

Specifications

Capacity	16 devices (Most Chromebooks, tablets*, or notebooks)	
Storage bays (nominal)	10"W [25.4 cm] x 15.5"D [39.38 cm] x 1.375"H [3.48 cm]	
Electrical	<ul style="list-style-type: none"> • 16-outlet power unit • 125V~/12A, 60Hz • 15-amp breaker • On/off switch 	<ul style="list-style-type: none"> • 15' nominal 14 AWG, 3-wire power cord • Dedicated compartment separates electrical line voltage from students • UL listed components
Certifications / Compliance	• Meets or exceeds applicable ANSI-BIFMA test standards	
Unit weight (nominal)	N/A	
Shipping weight (nominal)	N/A	

Specifications subject to change without notice

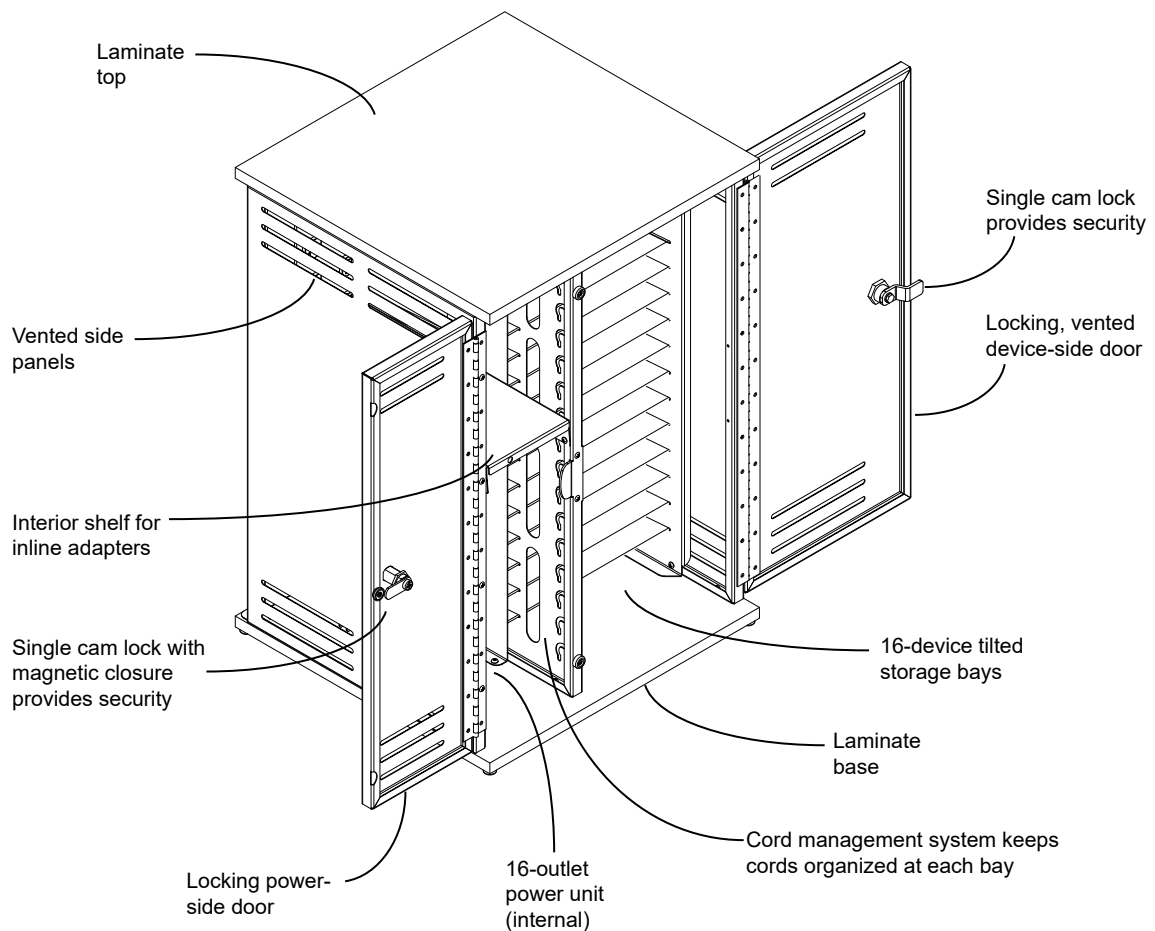

Outlet spacing on each
16-outlet power unit

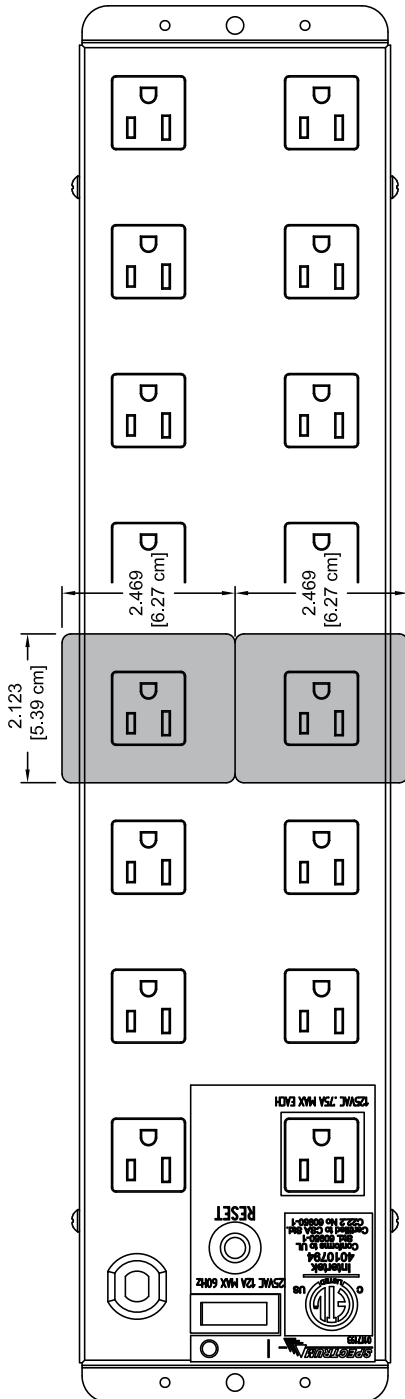

Total watts required per cart (estimated) = Number of devices X Charger wattage
(Max 1,800W)

⚠ Note: The customer should be aware of the amp draw of the devices used with this cart-especially when maxing out the storage and charging capacity. Exceeding 15 amps will trip the circuit breaker. Please consult the owners manual of your specific device for power consumption information.

USB-C PD Charger
(USB-C PD prewired only)

Specifications:

- Model: HA712
- Input: 100-240V ~ 50/60Hz 1.5A
- Output (USB-C PD): 5V~3A 9V~3A 12V~3A 15V~3A 20V~3.25A
- Dimensions: 1.97" x 1.97" x 1.10" (50mm x 50mm x 28mm)
- Net Weight: 3.42 oz [97 g]

Connect16 Locker

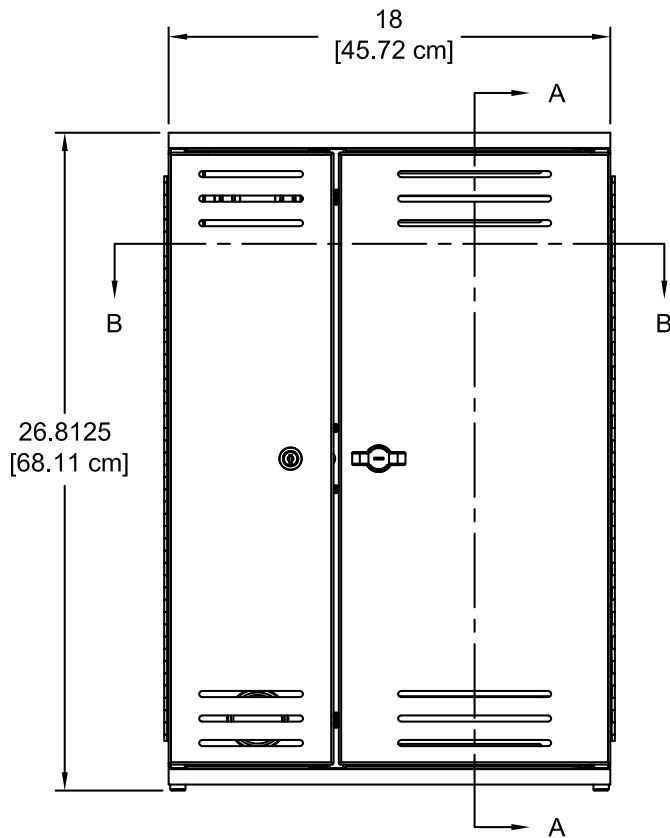
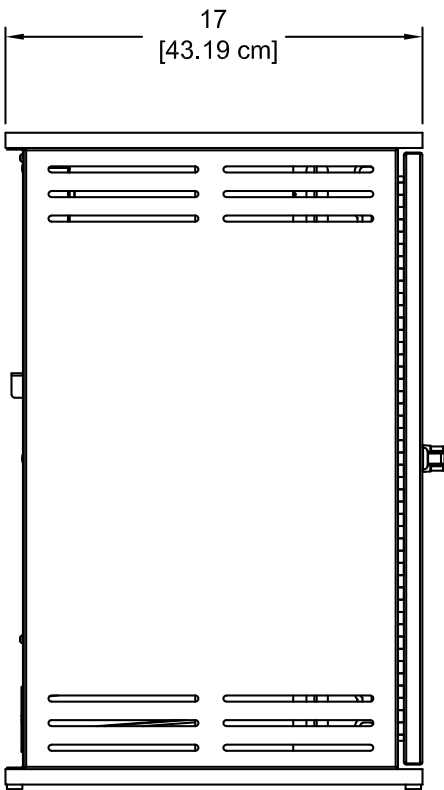
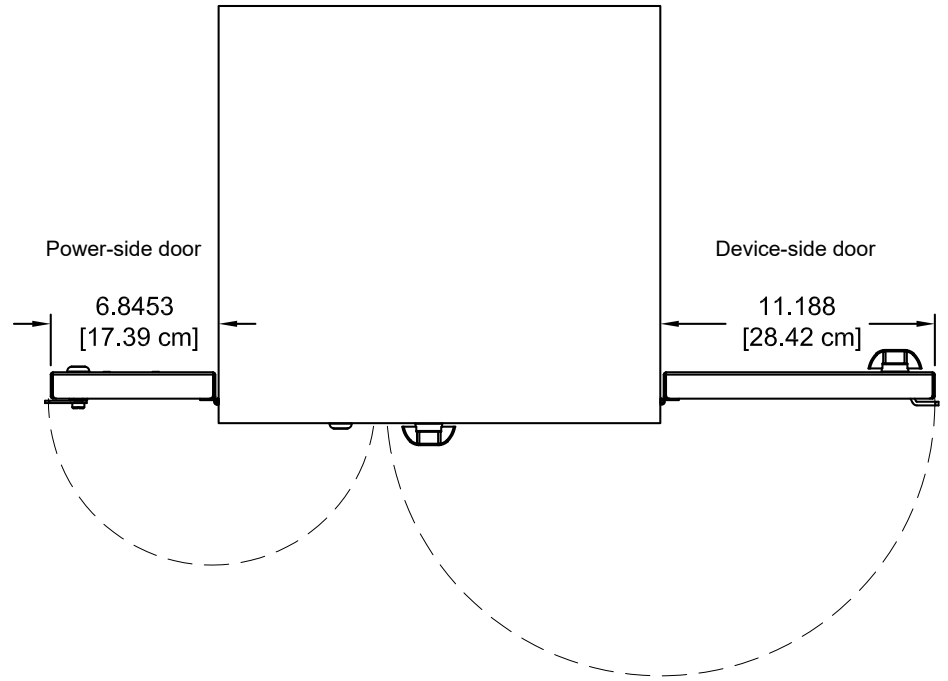
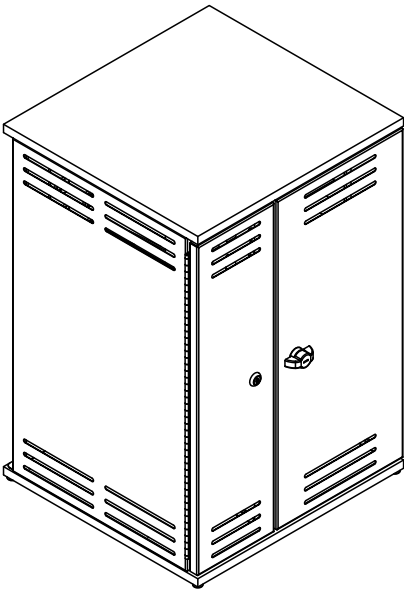

Section View A-A

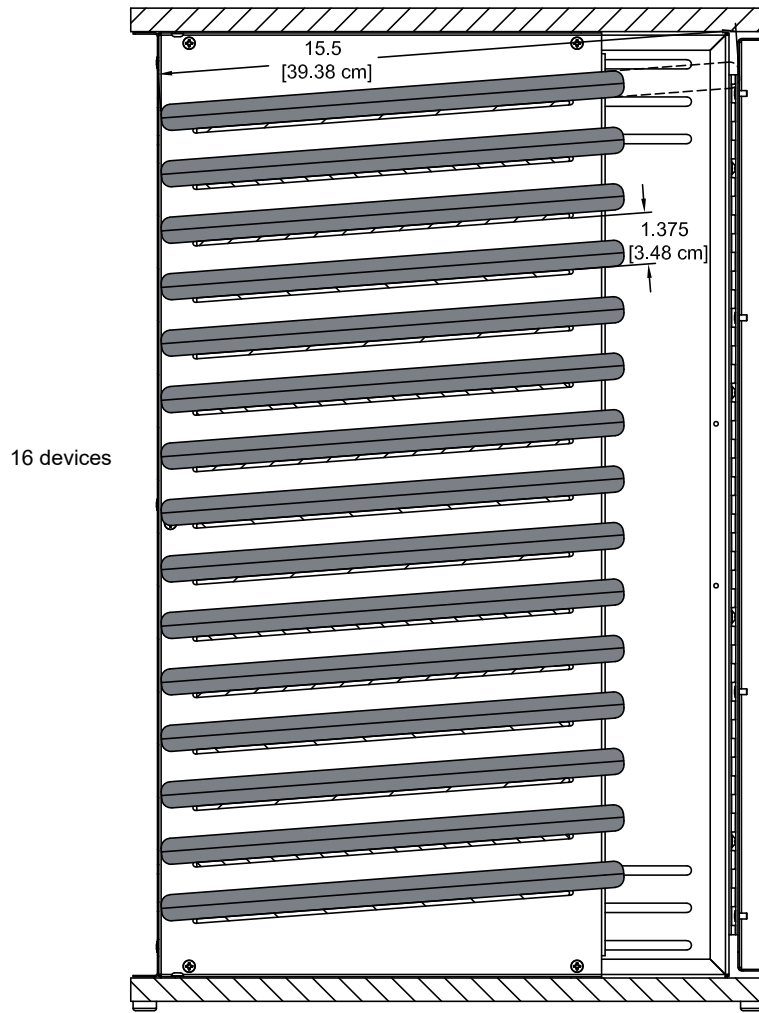

Section View B-B

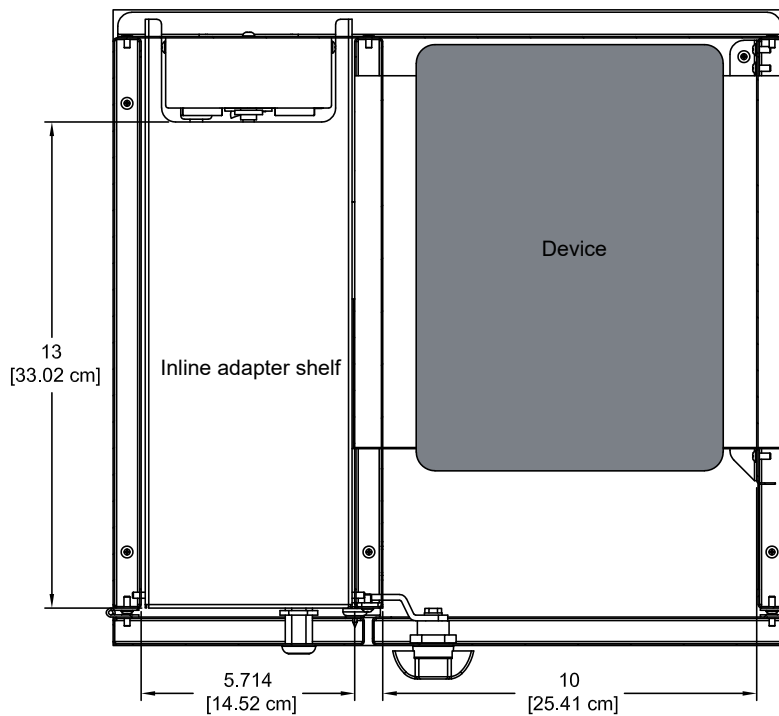

Interior view
(Shown with doors open)

Power-side

Device-side

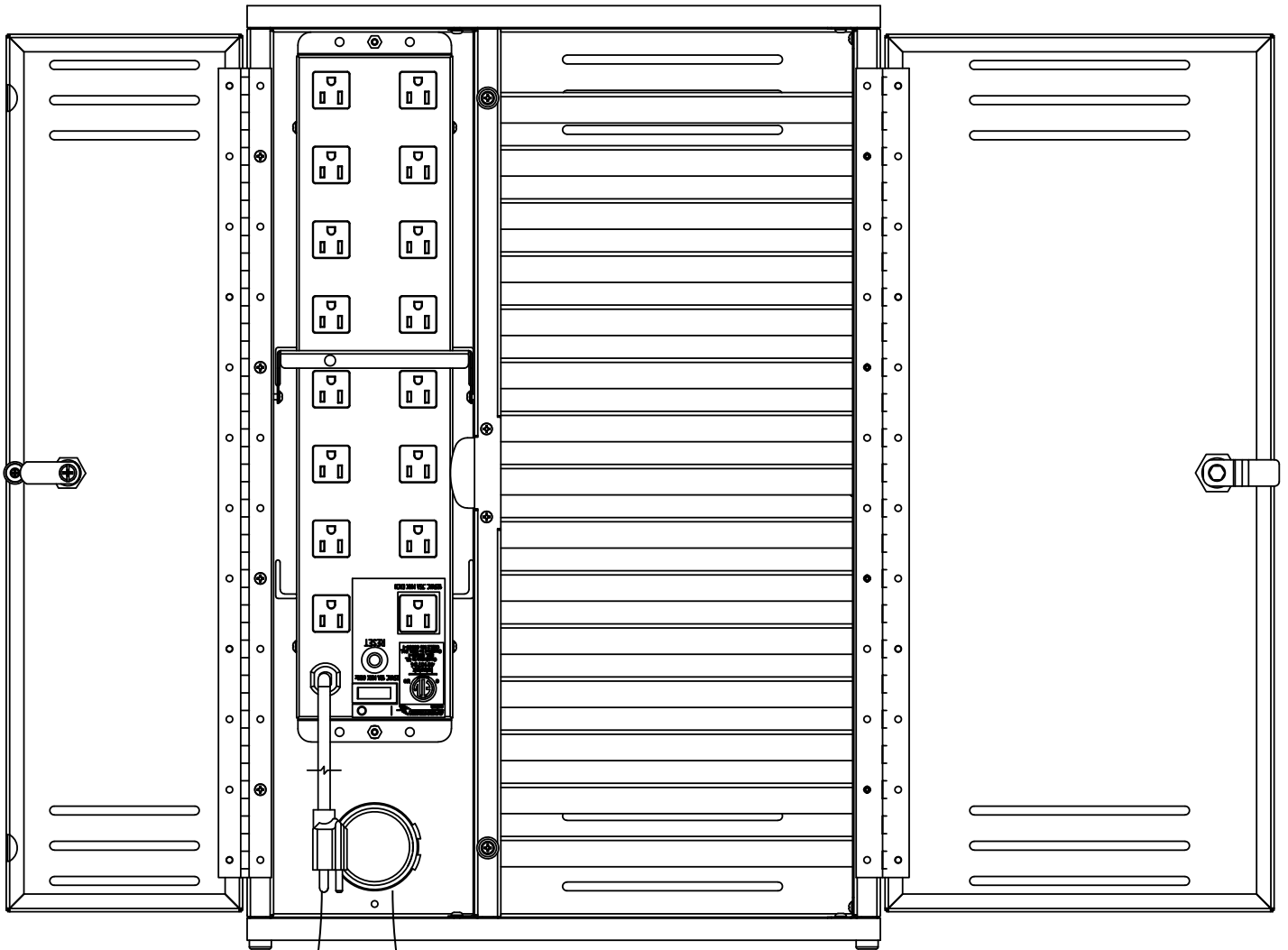

15' nominal 14 AWG,
3-wire power cord

Grommet on rear
panel for power
cord access

Warranty

We will make it right for you!

Thanks for choosing Spectrum! Spectrum is committed to provide complete customer satisfaction. Each of our products is manufactured from the best materials available and each product is stringently monitored throughout the production process through our P.A.C.E. program (Product Assurance to meet Customer Expectations).

We expressly warrant that Spectrum products will be of good quality and workmanship and free from defect for the period set out in the warranty from the date of delivery.

For a listing of all product specific warranty terms please visit our website at:

<https://www.spectrumfurniture.com/en/resources/purchasing-terms-warranty>

1-800-235-1262

Toll-free HELPLINE

spectrum@spectrumfurniture.com