

Assembly Instructions

⚠ Important ⚠

Before you begin, read and comply with all safety and operating instructions, and ensure all parts and correct quantities are included.

Any parts damaged during shipment must be reported within 5 days of receipt. To report information regarding missing parts or damage, to purchase parts or accessories, or if you have any questions, please contact us.

www.spectrumfurniture.com

800-235-1262, 715-723-6750

Thank you for purchasing Spectrum products!

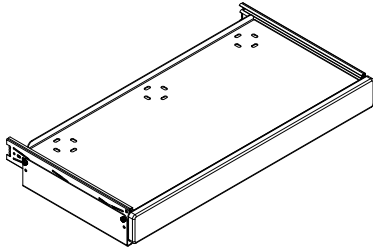

(1) 0120758
Keyboard Tray
Assembly



(4) 0100167
8-32 x 1/2" PH
Thread-cutting screw

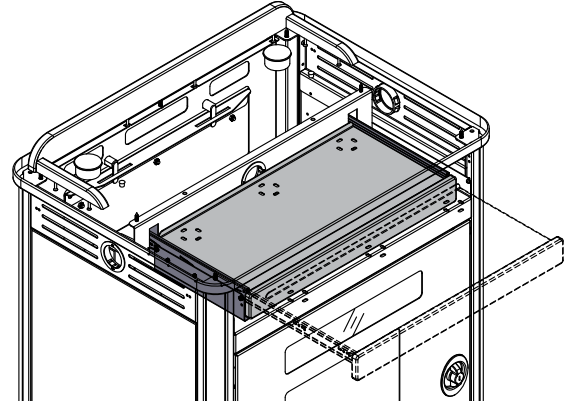

Keyboard Tray for Media Manager-Compact Lectern 55112

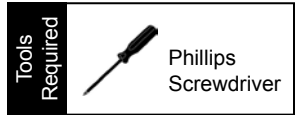

1. Align mounting holes

1. Set the keyboard tray onto the mid-panel and align the 4 mounting holes. **Figure 1.**

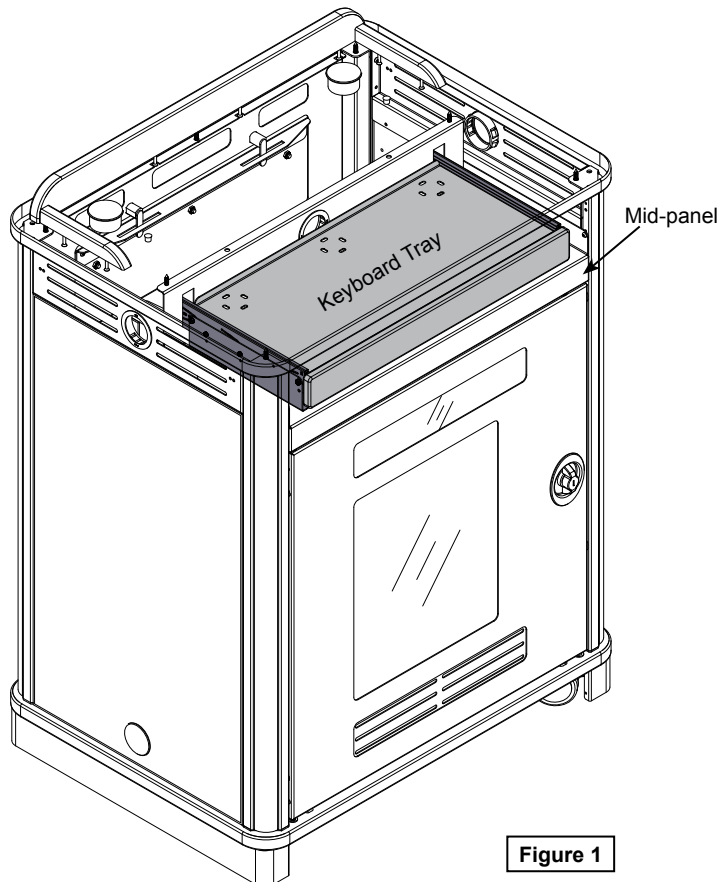
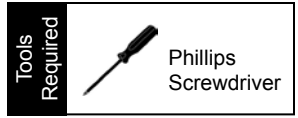

Figure 1

2. Install Screws



1. Open or remove the door(s) to access the mounting holes under the tray. (The rack cube can also be removed for improved access).
2. From inside the lectern, install the (4) 8-32 x 1/2" PH Thread-cutting screws through the mid-panel mounting holes to secure the tray, and tighten securely. **Figure 2.**

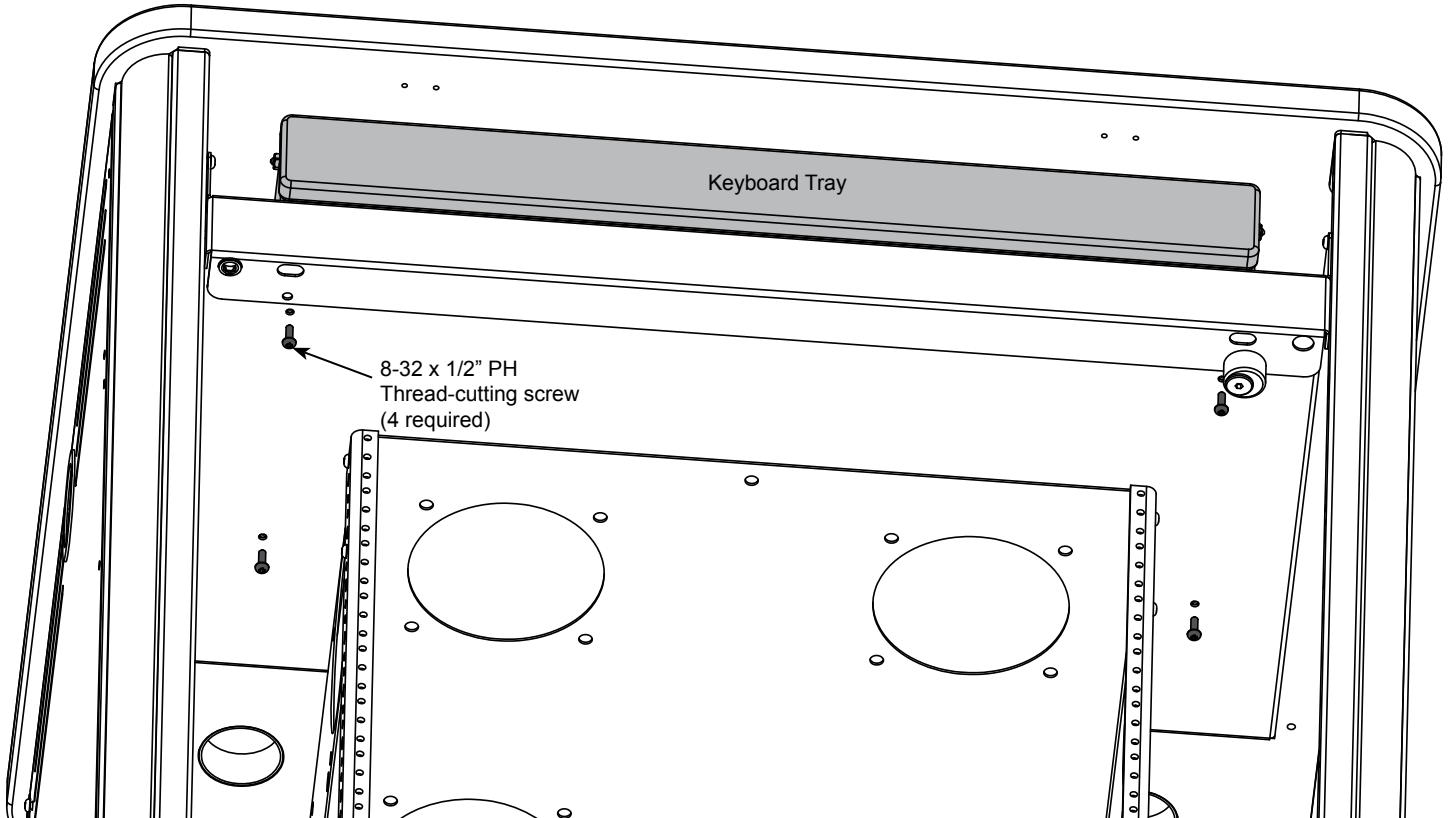

Figure 2

Flipping Keyboard Tray / Drawer - Optional

Note: Can be used as a keyboard tray, or flipped and used as a drawer.

1. To flip, pull the tray out fully and locate the black plastic lever on each slide. **Figure 3.**
2. Release the levers on the both slides while pulling the tray out.
3. Flip the tray over, re-align the slides, and push back in.

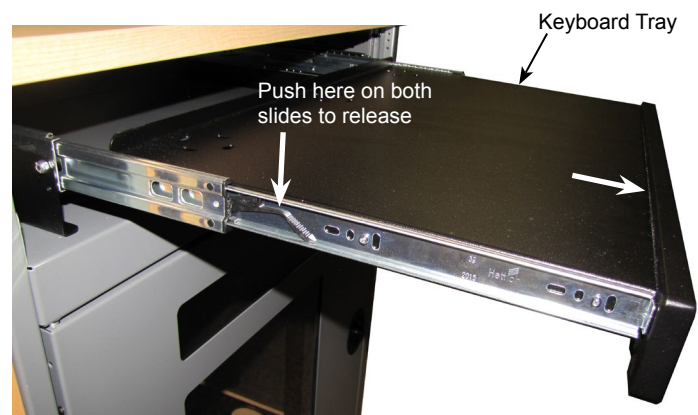

Figure 3