

# Assembly Instructions

## ⚠ Important ⚠

Before you begin, read and comply with all safety and operating instructions, and ensure all parts and correct quantities are included.

Any parts damaged during shipment must be reported within 5 days of receipt. To report information regarding missing parts or damage, to purchase parts or accessories, or if you have any questions, please contact us.

[www.spectrumfurniture.com](http://www.spectrumfurniture.com)

800-235-1262, 715-723-6750

Thank you for purchasing Spectrum products!

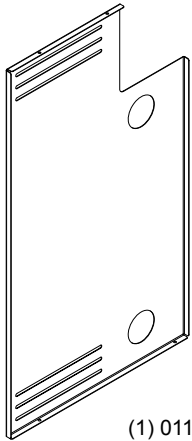

(1) 0119981  
Security Panel

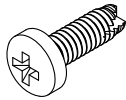

(2) 0100167  
8-32 x 1/2" PH  
thread-cutting screw

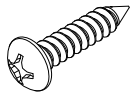

(2) 026073  
#8 x 3/4" PHSM



(2) 021588  
8-32 Keps nut

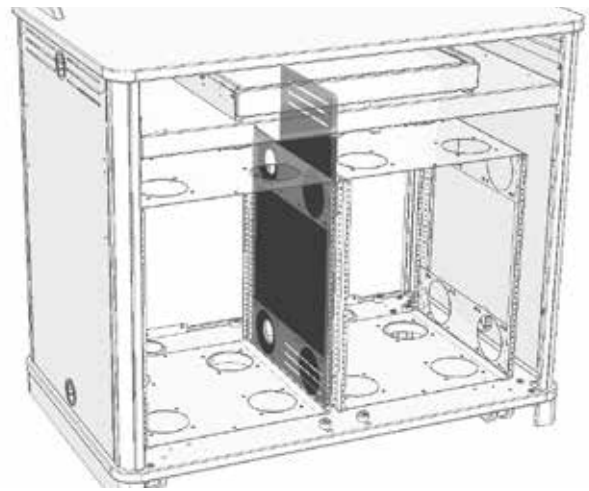

## Security Panel for Director Lectern

55383

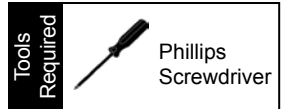

## Assembly

1. Open or remove the instructor-side doors and remove any rack cubes.
2. Remove the keyboard tray by releasing the levers on the slides while pulling the tray out.
3. Place the panel inside lectern as shown (notch toward audience-side) and align the mounting holes. **Figure 1**.
4. Install (2) 8-32 x 1/2" PH thread-cutting screws from above into the panel.
5. Install (2) #8 x 3/4" PHSM screws into the base panel.
6. Install (2) 8-32 Keps Nuts onto the screws from step 4.
7. Tighten all fasteners securely and replace the keyboard tray.

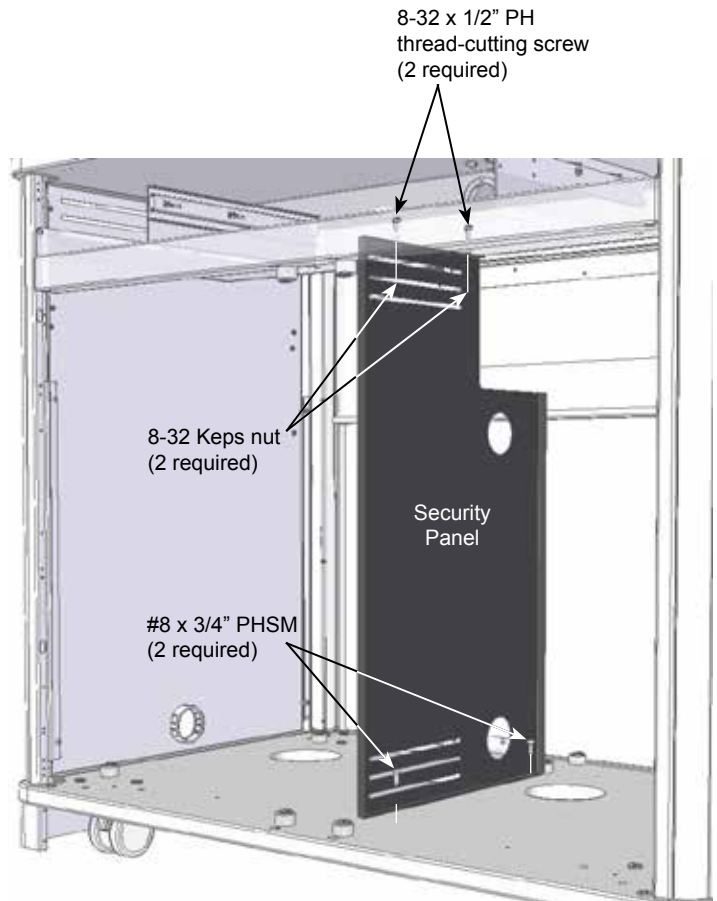

Figure 1