

Assembly Instructions

⚠ Important ⚠

Before you begin, read and comply with all safety and operating instructions, and ensure all parts and correct quantities are included.

Any parts damaged during shipment must be reported within 5 days of receipt. To report information regarding missing parts or damage, to purchase parts or accessories, or if you have any questions, please contact us.

www.spectrumfurniture.com
800-235-1262, 715-723-6750

Thank you for purchasing Spectrum products!

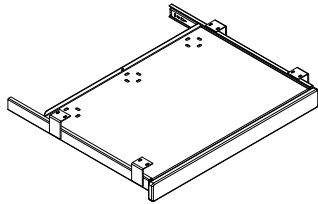

(1) 0114290
Keyboard Tray

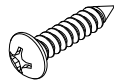

(8) 026073
#8 x 3/4" PHSM Screw



(3) 052608
3/4" x 5" Hook & Loop
Strap

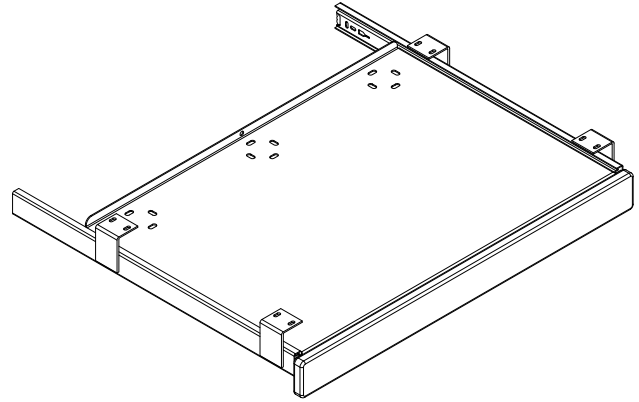

Keyboard Tray
55356

Installation

1. If possible, install the keyboard tray with the worksurface face down.
2. Pull the keyboard tray slides out and align the slide bracket mounting holes with the pre-drilled worksurface mounting holes.

Figure 1.

Note: If the worksurface does not have predrilled mounting holes, use the slide brackets as a template to mark the mounting hole locations onto the worksurface with a pencil, then drill each hole location with a 1/8" drill bit about 3/4" deep. Be careful not to drill completely through the worksurface.

3. Install (8) #8 x 3/4" PHM screws through the slide brackets and tighten securely.
4. Use slots in tray & Velcro straps to secure cords.

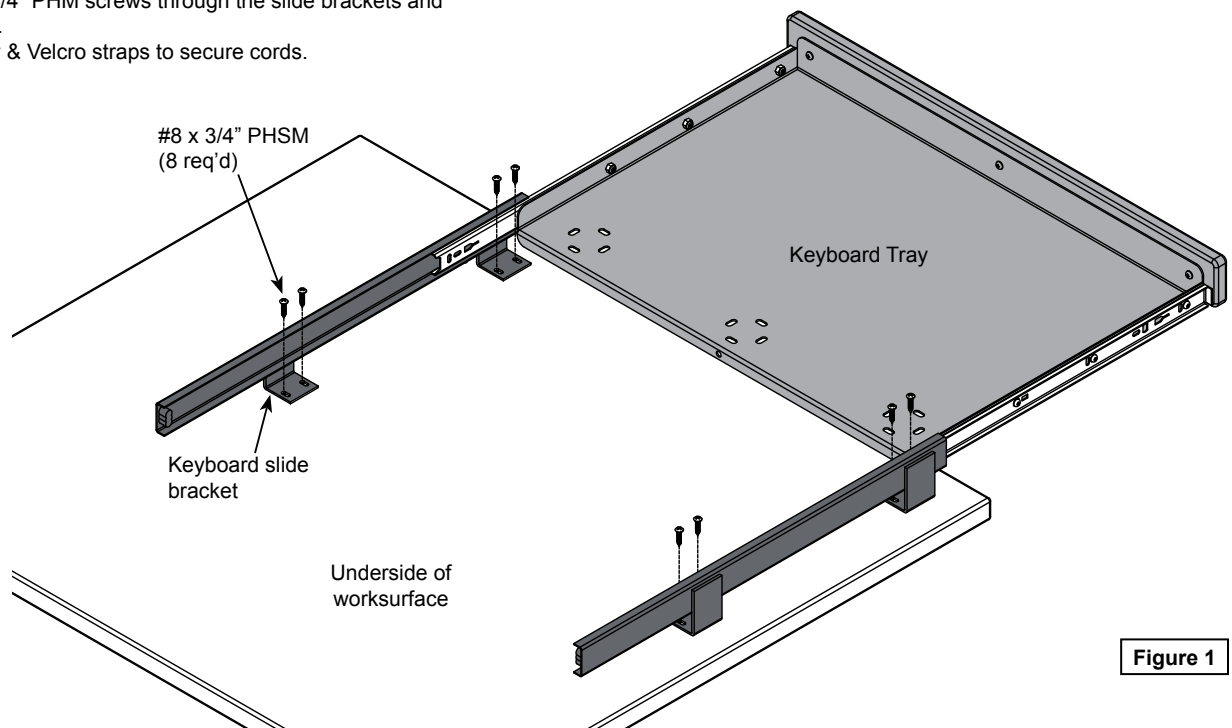
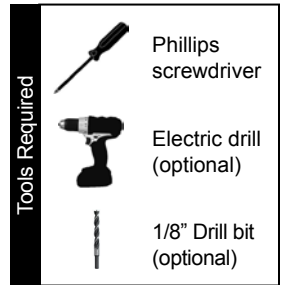

Figure 1