

Assembly Instructions

⚠ Important ⚠

Before you begin, read and comply with all safety and operating instructions, and ensure all parts and correct quantities are included.

Any parts damaged during shipment must be reported within 5 days of receipt. To report information regarding missing parts or damage, to purchase parts or accessories, or if you have any questions, please contact us.

www.spectrumfurniture.com
800-235-1262, 715-723-6750

Thank you for purchasing Spectrum products!

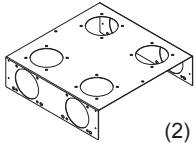

(2) 0118596
Top / Bottom Panel



(1) 0101382
#14 x 7/8" PHSM
screw

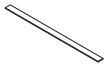

(2) 0115173
1"W x 18.5"L
Polyethylene slide
with (S1101) 3/4"
double-sided tape



(16) 0100167
8-32 x 1/2" PH
thread-cutting
screw

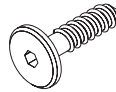

(4) 0102297
7mm x 30mm
JCW screw

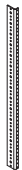

(4) 044922
Rack rail (26.25")



(4) 0107139
Bumper Stop



(1) 025039
4mm Hex
wrench

Tools Required



Drill with
Phillips
driver



Phillips
Screwdriver



4mm Hex
Wrench
(included)

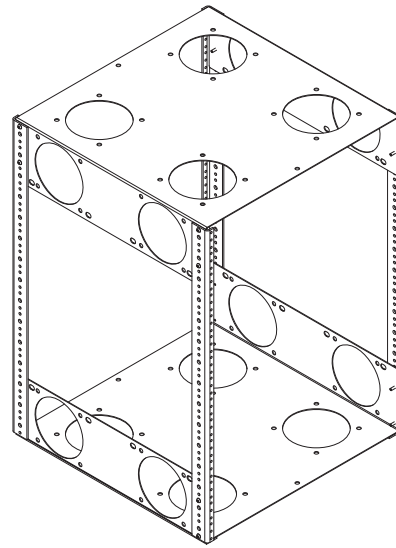

15RU Rack Cube 55384

1. Assemble Cube

1. Assemble the cube top / bottom panels, and (4) rack rails using (16) 8-32 x 1/2" PH thread-cutting screws. Note the orientation of the rails. **Figure 1.**
2. Tighten screws securely.

2. Apply Slides

1. Apply the polyethylene slides to the bottom panel as shown. **Figure 2.**

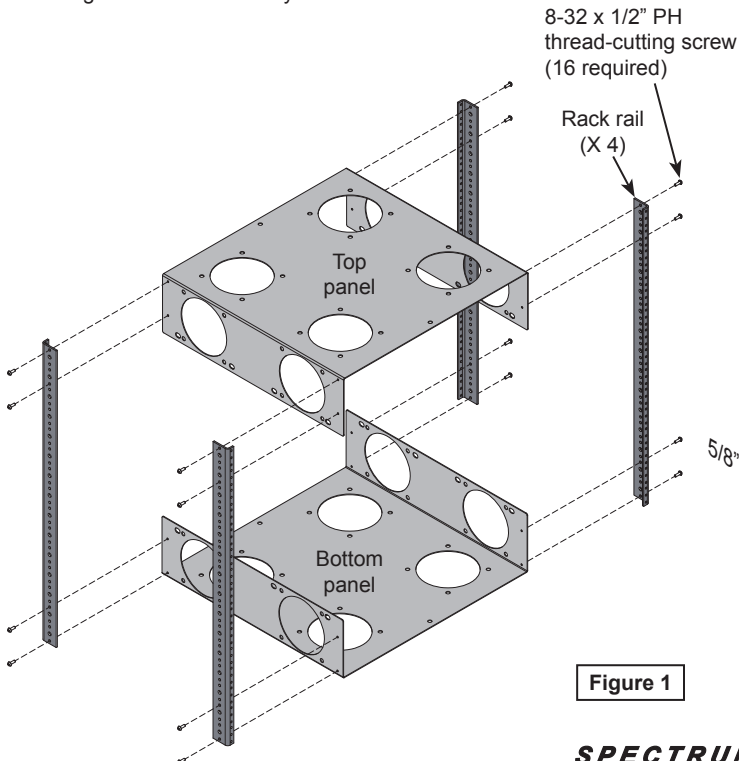

Figure 1

Note: Each slide should be placed approximately 5/8" away from the edge of the rack cube.

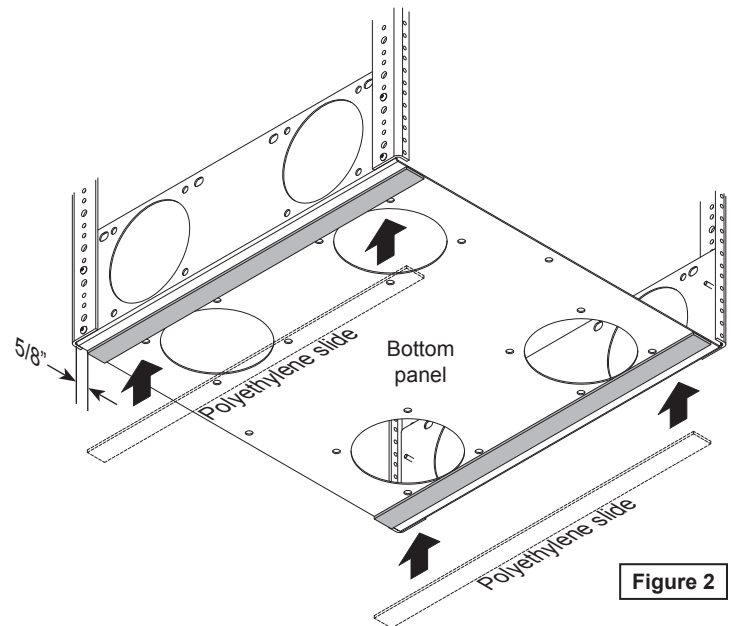

Figure 2

3. Install Cube

1. Using the quick-release, remove the door to provide better access.
2. Install the (4) bumper stops to the base panel as shown with one 7mm x 30mm JCW screw each. **Figure 3.**
3. Place the cube assembly into the lectern.
4. Secure the cube to the base panel with (1) #14 x 7/8" PHSM screw and tighten securely.
5. The bumper stops can be rotated if adjustment is necessary.

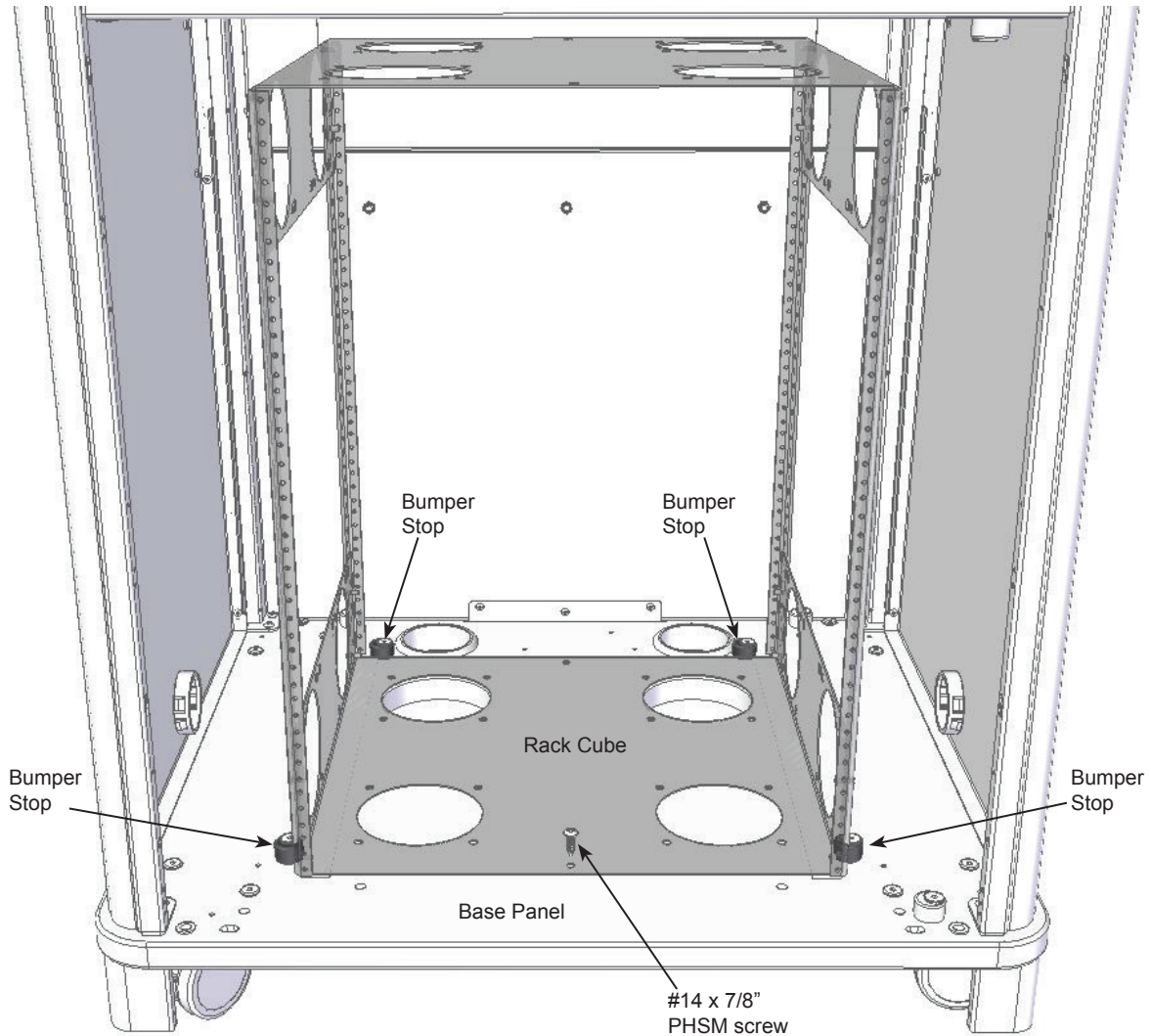

Figure 3

The rack cube provides 15RU of rack space and is easily removed from the lectern. This simplifies installation of equipment and provides the ability to integrate equipment remotely. The cube can be installed into the lectern at a later date or when convenient.

The cube also provides mounting capabilities for multiple cooling fans if necessary. Compatible with most 4.75" cooling fans with 4.13" mounting hole spacing (12 mounting locations available).