

# Assembly Instructions

## ⚠ Important ⚠

Before you begin, read and comply with all safety and operating instructions, and ensure all parts and correct quantities are included.

Any parts damaged during shipment must be reported within 5 days of receipt. To report information regarding missing parts or damage, to purchase parts or accessories, or if you have any questions, please contact us.

[www.spectrumfurniture.com](http://www.spectrumfurniture.com)  
800-235-1262, 715-723-6750

*Thank you for purchasing Spectrum products!*

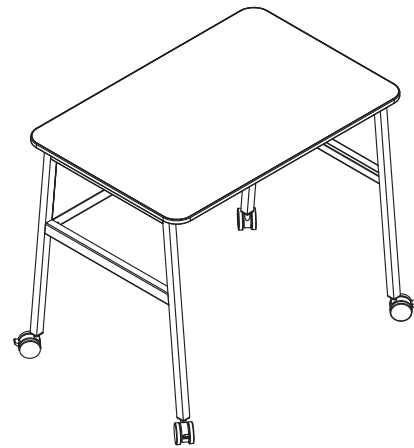

## Table for Aspire Workstation 37430

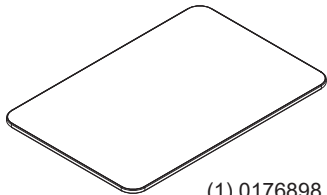

(1) 0176898  
Worksurface

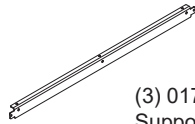

(3) 0171406  
Support bracket

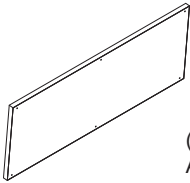

(1) 0171352  
Audience-side  
panel

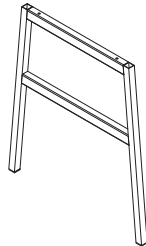

(2) 0171350  
Leg

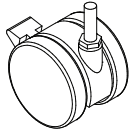

(4) 0105662  
60mm 5/16-18 x 1"  
Stem Caster



(22) 035594  
#10 x 5/8"  
PHSM



**Assembly tip:** Do not tighten component fasteners completely until all have been installed. Keeping them loose will help with alignment between parts during assembly.

## 1 Attach casters to legs

1. Attach casters to legs and tighten.

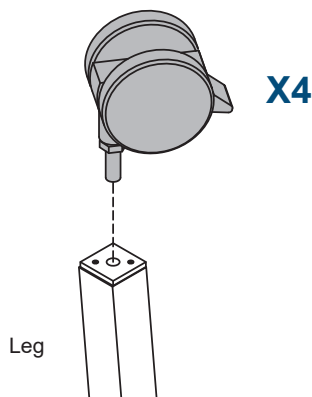

## 2 Attach legs to work surface

1. Place the work surface face-down onto a non-abrasive surface.
2. Orient the legs as shown with the flange toward the center.
3. Attach each leg to the work surface with (2) screws.

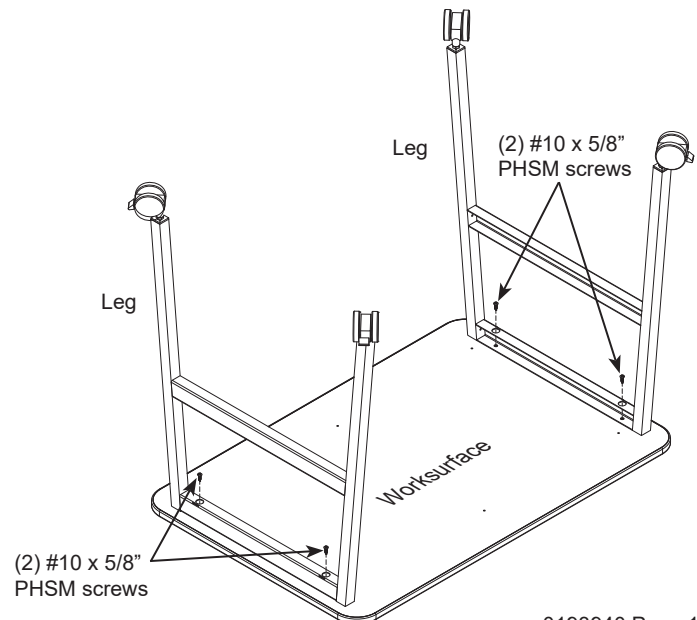

### 3 Install support brackets

1. Attach (2) of the support brackets to the worksurface as shown with (3) screws each.
2. Install (1) screw at each corner to secure to the legs.
3. Attach the 3rd support bracket between the legs and secure with a screw at each end.

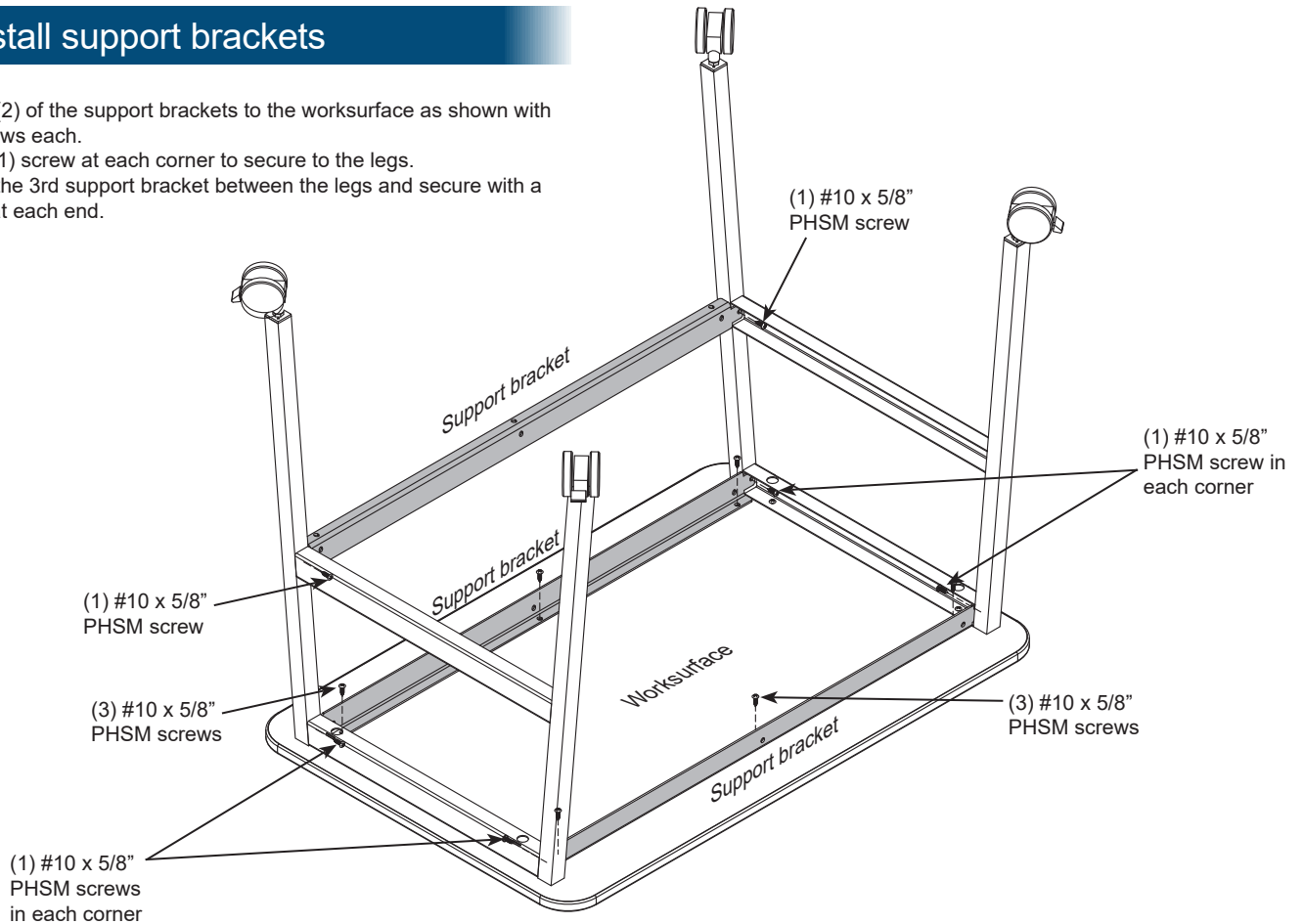

### 4 Attach audience-side panel

1. Attach the panel to the support brackets with (6) screws.

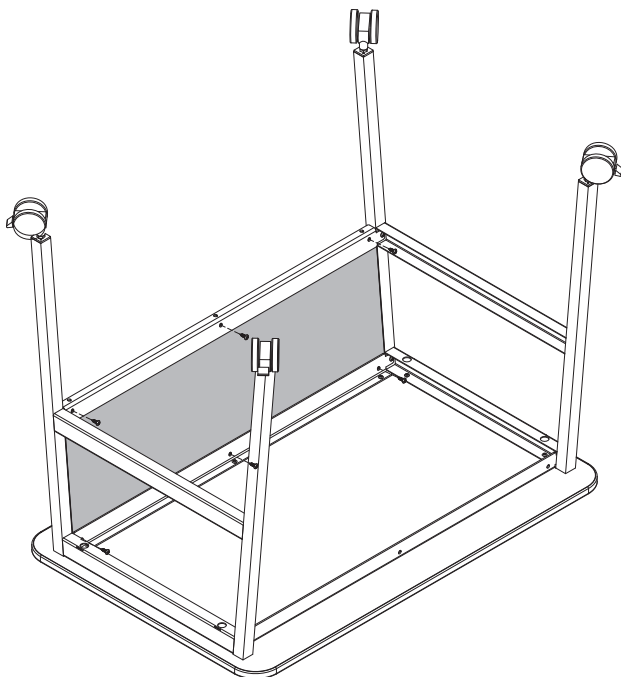

### 5 Flip table upright

1. Carefully flip the table upright. This may take 2 people.

